

The Robert Sorby Multi-Tip Hollowing Tool is a handy addition to any tool kit. It comes complete with three replaceable cutters - two for hollowing, one for scraping. Of the two hollowing cutters, the one with the rounded end is designed for general roughing out and will create a flowing curve as in the bottom of a vessel. The more pointed cutter is for fast material removal and also produces a crisp corner in a box.

HOLLOWING

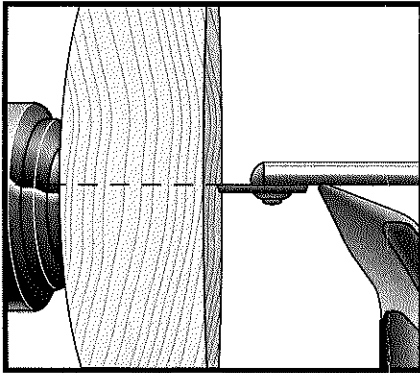

1. With tool rest on centre, place the flat face of the Multi-Tip tool on the rest. This gives more control and allows aggressive hollowing.

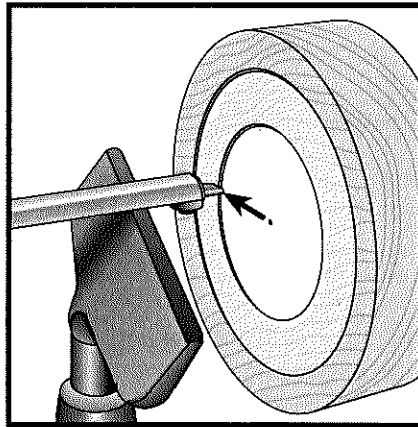

2. From the centre work the tool outwards to the required size.

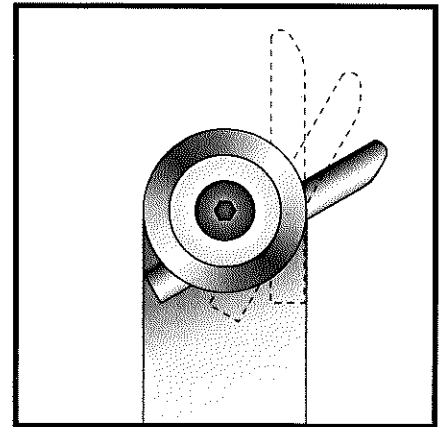

3. Angle of the cutter can be adjusted through 360°.

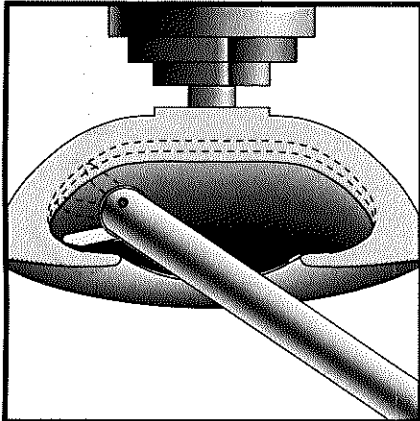

4. This makes the Multi-Tip ideal for under-cutting.

SCRAPING

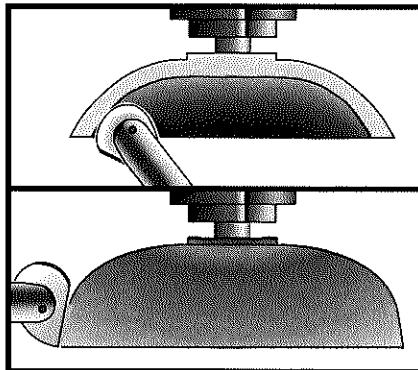

5. Fit scraper cutter using allen screw provided. Rotate cutter to required face - round faces for internal work, square face for external finishing.

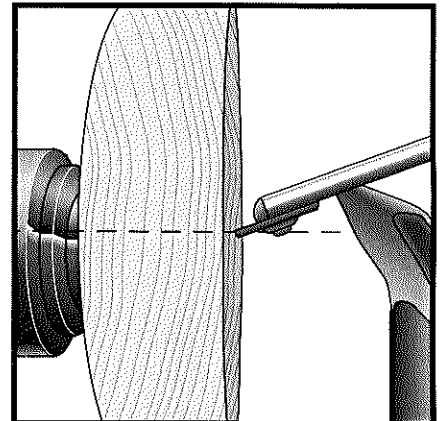

6. Place tool rest slightly above centre and with the flat surface of the tool on the rest trail the tool by approximately 5°.

SHARPENING

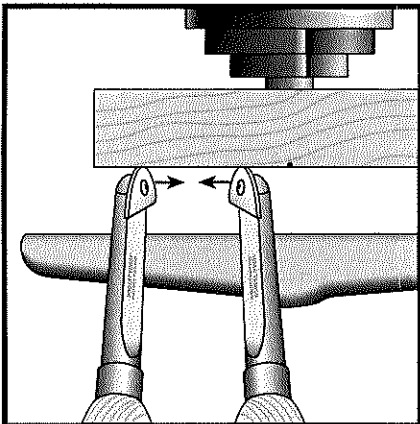

7. To create an even finer finish angle the tool at 45° on its curved back and work in either direction, this produces a slicing cut. Tool rest should be above centre.

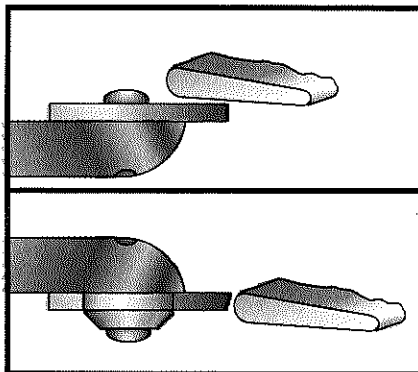

8. For maximum performance hone the cutters frequently. For the perfect sharp edge use the cutter holder (ref. 472) in conjunction with the Robert Sorby Pro-Edge.

A brief video clip of this tool in action is available on www.robert-sorby.co.uk