

## Original Instructions

# BDS250 10" x 6" Belt & Disc Sander

Version 3.1  
November 2022



Show with optional stand and wheel kit.



To register this product please visit  
[www.recordpower.info](http://www.recordpower.info)

It is important to register your product as soon as possible in order to receive efficient after sales support and be entitled to the full **5 year guarantee**. Your statutory rights are not affected. Please see back cover for contact details.



Always wear safety glasses when using woodworking equipment.



Always read the instructions provided before using woodworking equipment.



### Important

For your safety read instructions carefully before assembling or using this product. Save this manual for future reference.

# Contents

- 1 Explanation of Symbols
  - 2 General Health & Safety Guidance
  - 3 Additional Health & Safety for Belt & Disc Sanders
  - 4 Record Power Guarantee
  - 5 Machine Specifications
  - 6 Unpacking & Checking Contents
  - 7 Assembly Instructions
  - 8 Getting to Know your Belt & Disc Sander
  - 9 No Volt Switch
  - 10 Basic Operation
  - 11 Maintenance
  - 12 Troubleshooting
  - 13 Dust Extraction
  - 14 Electrical Connection & Wiring Diagram
  - 15 Exploded Diagram & Parts List
  - 16 Assembly of the Optional BDS250-A Stand
  - 17 Assembly of the Optional BDS250-W Wheel Kit
- EU Declaration of Conformity
- UKCA Declaration of Conformity

# 1. Explanation of Symbols

**THE SYMBOLS AND THEIR MEANINGS SHOWN BELOW MAY BE USED THROUGHOUT THIS MANUAL. PLEASE ENSURE THAT YOU TAKE THE APPROPRIATE ACTION WHEREVER THE WARNINGS ARE USED.**

## Mandatory Instructions



Read and fully understand the instruction manual before attempting to use the machine.



Indicates an instruction that requires particular attention



Wear protective eyewear



Use respiratory protective equipment



Use hearing protection



Use suitable protective footwear



Use protective work gloves

## Warning



Indicates a risk of severe personal injury or damage to the machine



Indicates a risk of severe personal injury from electrical shock



Risk of personal injury from lifting of heavy items



Indicates a risk of severe personal injury from airborne objects



Risk of fire

# 2. General Health & Safety Guidance

**Ensure that you carefully read and fully understand the instructions in this manual before assembly, installation and use of this product. Keep these instructions in a safe place for future reference.**

**WARNING:** for your own safety, do not attempt to operate this machine until it is completely assembled and installed according to these instructions.

**WARNING:** When using any machine, basic safety precautions should always be followed to reduce the risk of fire, electric shock and personal injury.

## Safe Operation

### 1. Use Personal Protective Equipment (PPE)

- The operation of any machine can result in foreign objects being thrown into your eyes, which can result in severe eye damage. Protective eyewear or other suitable eye protection or face shield should be used at all times. Everyday spectacles only have impact resistant lenses. They are not protective eyewear and do not give additional lateral protection.
- Use respiratory protective equipment (dust mask etc.) if the machining operation creates dust. Exposure to high levels of dust created by machining hardwoods, softwoods and man made composite boards can result in serious health problems. Some imported hardwoods give off highly irritating dust, which can cause a burning sensation. The use of respiratory protective equipment should not be seen as an alternative to controlling the risk of exposure at source by using adequate dust extraction equipment.
- The use of ear plugs or ear defenders is recommended when the machine is in use, particularly if the noise level exceeds 85 dB.
- Wear suitable protective gloves when handling cutting tools or blades. Gloves should NOT be worn when using the machine as they can be caught in moving parts of the machine.
- Non-slip safety footwear is recommended when using the machine and handling large work pieces.

### 2. Dress appropriately

- Do not wear loose clothing, neckties or jewellery; they can be caught in moving parts of the machine.
- Roll up long sleeves above the elbow.
- Wear protective hair covering to contain long hair.

### 3. Safety warnings

- Find and read any warning labels on the machine.
- It is important that any labels bearing health and safety warnings are not removed, defaced or covered. Replacement labels can be obtained by contacting our Customer Service Department.

### 4. Familiarise yourself with the machine

- If you are not thoroughly familiar with the operation of this machine, obtain advice from your supervisor, instructor, or other qualified person or contact your retailer for information on training courses. Do not use this machine until adequate training has been undertaken.

### 5. Take care when moving or positioning the machine

- Some machines can be very heavy. Ensure the floor of the area in which the machine is to be used is capable of supporting the machine.
- The machine and its various components can be heavy. Always adopt a safe lifting technique and seek assistance when lifting heavy components. In some cases it may be necessary to use mechanical handling equipment to position the machine within the work area.
- Some machines have optional wheel kits available to allow them to be manoeuvred around the workshop as required. Care should be taken to install these according to the instructions provided.
- Due to the nature of the design of some machines the centre of gravity will be high making them unstable when moved. Extreme care should be taken when moving any machine.
- If transportation of the machine is required then all precautions relating to the installation and handling of the machine apply. In addition, ensure that any vehicles or manual handling equipment used for transportation are of adequate specification.

### 6. The machine should be level and stable at all times

- When using a leg stand or cabinet base that is designed to be fitted to the machine, always ensure that it is securely fastened to the machine using the fixings provided.
- If the machine is suitable to be used on a workbench, ensure that the workbench is well constructed and capable of withstanding the weight of the machine. The machine should always be securely fastened to the workbench with appropriate fixings.
- Where possible, floor standing machines should always be secured to the floor with fixings appropriate to the structure of the floor.

## 2. General Health & Safety Guidance - cont.

- The floor surface should be sound and level. All of the feet of the machine should make contact with the floor surface. If they do not, either re-locate the machine to a more suitable position or use packing shims between the feet and the floor surface to ensure the machine is stable.
- 7. Remove adjusting keys and wrenches**
- Ensure that all adjusting wrenches and keys are removed before switching the machine 'ON'. There is a risk of severe personal injury or damage to the machine from airborne objects.
- 8. Before switching the machine 'ON'**
- Clear the machine table of all objects (tools, scrap pieces etc.)
  - Make sure there is no debris between the work piece and the table / work support.
  - Ensure that the work piece is not pressed against, or touching the saw blade or cutting tool.
  - Check all clamps, work holding devices and fences to ensure that they are secure and cannot move during machining operations.
  - Plan the way that you will hold and feed the work piece for the entire machining operation.
- 9. Whilst machining**
- Before starting work, watch the machine while it runs. If it makes an unfamiliar noise or vibrates excessively, switch the machine 'OFF' immediately and disconnect it from the power supply. Do not restart until finding and correcting the source of the problem.
- 10. Keep the work area clear**
- Working clearances can be thought of as the distances between machines and obstacles that allow safe operation of every machine without limitation. Consider existing and anticipated machine needs, size of material to be processed through each machine and space for auxiliary stands and/or work tables. Also consider the relative position of each machine to one another for efficient material handling. Be sure to allow yourself sufficient room to safely operate your machines in any foreseeable operation.
  - Cluttered work areas and benches create the risk of accidents. Keep benches clear and tidy away tools that are not in use.
  - Ensure that the floor area is kept clean and clear of any dust and debris that may create trip or slip hazards.
- 11. Consider the work area environment**
- Do not expose the machine to rain or damp conditions.
  - Keep the work area well lit and ensure that there is artificial lighting available when there is insufficient natural light to effectively light the work area. Lighting should be bright enough to eliminate shadow and prevent eye strain.
  - Do not use the machine in explosive environments eg. in the presence of flammable liquids, gases or dust.
  - The presence of high levels of dust created by machining wood can present a risk of fire or explosion. Always use dust extraction equipment to minimise the risk.
- 12. Keep other persons away (and pets)**
- The machine is designed to be used by one person only.
  - Do not let persons, especially children, touch the machine or extension cable (if used) and keep visitors away from the work area.
  - Never leave the machine running unattended. Turn the power supply off and do not leave the machine unattended until it comes to a complete stop.
  - If the work area is to be left unattended, all machinery should be switched 'OFF' and isolated from the mains power supply.
- 13. Store machines safely when not in use**
- When not in use, machines should be stored in a dry place, out of reach of children. Do not allow persons unfamiliar with these instructions or with the machine to operate it.
- 14. Do not overreach**
- Choose a working position that allows your body to remain balanced and feed the work piece in to the machine without overreaching.
  - Keep proper footing and balance at all times.
- 15. Electrical supply**
- Electrical circuits should be dedicated to each machine or large enough to handle combined motor amp loads. Power outlets should be located near each machine so that power or extension cables are not obstructing high-traffic areas. Observe local electrical guidelines for proper installation of new lighting, power outlets, or circuits.
  - The machine must be connected to an earthed power supply.
  - The power supply must be equipped with a circuit breaker that provides short circuit, overload and earth leakage protection.
  - The voltage of the machine must correspond to the voltage of the mains power supply.
  - The mains plug fitted to the machine should always match the power outlet. Do not modify the plug in any way. If a replacement plug is required it should be fitted by a competent person and of the correct type and rating for the machine.
  - If you are unsure about any electrical connections always consult a qualified electrician.
- 16. Avoid unintentional starting of the machine**
- Most machines are fitted with a no-volt release (NVR) switch to prevent unintentional starting. If in doubt always ensure the machine switch is in the 'OFF' position before connecting it to the power supply. This means the machine will not automatically start up after a power cut or switching on of the power supply, unless you first reset the start switch.
- 17. Outdoor use**
- Your machine should not be used outdoors.
- 18. Extension cables**
- Whenever possible, the use of extension cables is not recommended. If the use of an extension cable is unavoidable, then it should have a minimum core cross section of 2.5 mm<sup>2</sup> and limited to a maximum length of 3 metres.
  - Extension cables should be routed away from the direct working area to prevent a trip hazard.
- 19. Guard against electric shock**
- Avoid body contact with earthed or grounded surfaces such as pipes and radiators. There is an increased risk of electric shock if your body is earthed or grounded.
- 20. Always work within the machine's intended capacities**
- Operator safety and machine performance are seriously adversely affected if attempts to make the machine perform beyond its limits are made.
- 21. Do not abuse the power cable**
- Never pull the power cable to disconnect it from the power socket. Always use the plug.
  - Keep the power cable away from heat, oil and sharp edges.
  - Do not use the power cable for carrying or moving the machine.
- 22. Secure the work piece**
- Ensure that the work piece is securely held before starting to machine it.
  - When working within 300 mm of the machining area, always use a push stick to feed the work piece in to the blade or cutting tool. The push stick should have a minimum length of 400 mm. If the push stick becomes damaged, replace it immediately.
  - Use extra supports (roller support stands etc.) for any work pieces large enough to tip when not held down to the table top.
  - Do not use another person as a substitute for a table extension, or as additional support for a work piece that is longer or wider than the basic table, or to help feed, support, or pull the work piece.
  - Do not attempt to machine more than one work piece at a time.
  - When feeding the work piece towards the blade or cutting tool never position your hands in direct line of the cutting path. Avoid awkward operations and hand positions where a sudden slip could cause your hand or fingers to move into the machining area.
- 23. Stay alert**
- Safety is a combination of operator common sense and alertness at all times when the machine is being used.

## 2. General Health & Safety Guidance - cont.

- Use all machines with extreme care and do not use the machine when you are tired or under the influence of drugs, alcohol or medication.

### 24. Use the correct tool for the job

- Do not use the machine for any purpose other than which it was designed.
- When selecting replacement cutting tools and blades, always ensure that they are designed to cut the material that you intend to use them for. If in any doubt seek further advice from the manufacturer.

### 25. Connect dust extraction equipment

- Always use dust extraction equipment. The dust extractor should be of suitable size and capacity for the machine that it is connected to and have a filtration level appropriate to the type of waste being collected. Refer to the relevant section of the manual for details of the specific dust extraction requirements for this machine.
- The dust extractor should be switched 'ON' before starting the machine that it is connected to. The dust extractor should be left running for 30 seconds after the last machining operation is complete in order to clear any residual waste from the machine.

### 26. Ensure that the machine is correctly guarded

- Never use the machine if any of the standard safety guards and equipment are removed or damaged.
- Some machines incorporate safety interlocks to prevent the machine from being used without the guards in place. Never attempt to bypass or modify the interlocks to allow the machine to be used without the guards in place.

### 27. Maintain your machine with care

- This manual gives clear instructions on installation, set up and operation of the machine and also details any routine and preventative maintenance that should be performed periodically by the user.
- Remember always to switch off and unplug the machine from the power supply before carrying out any setting up or maintenance operations.
- Follow any instructions for the maintenance of accessories and consumables.
- Do not use compressed air to clean the machine. Always use a brush to dislodge dust in places that are awkward to reach and a dust extractor to collect the waste.
- Inspect electric cables periodically and, if damaged, have them replaced by an authorised service facility or qualified electrician.
- Inspect extension cables (if used) periodically and replace if damaged.

### 28. Keep cutting tools sharp and clean

- Correctly maintained cutting tools are easier to control and less likely to bind.
- Cutting tools and blades can become hot during use. Take extreme care when handling them and always allow them to cool before changing, adjusting or sharpening them.

### 29. Disconnect the machine from the power supply

- When not in use, before servicing, changing blades etc. always disconnect the machine from the power supply.

### 30. Check for damaged parts

- Before each use of the machine, it should be carefully checked to determine that it will operate properly and perform its intended function.
- Check for alignment of moving parts, binding of moving parts, breakage of parts and any other conditions that may affect the operation of the machine.
- A guard or other part that is damaged should be properly repaired or replaced by a qualified person unless otherwise indicated in this instruction manual.
- Do not use the machine if the switch does not turn the machine 'ON' and 'OFF'.
- Have defective switches replaced by a qualified person.

### 31. Warning!

- The use of any accessory or attachment, other than those recommended in this instruction manual, or recommended by our Company may present a risk of personal injury or damage to the machine and invalidation of the warranty.

### 32. Have your machine repaired by a qualified person

- This machine complies with the relevant safety rules and standards appropriate to its type when used in accordance with these instructions and with all of the standard safety guards and equipment in place. Only qualified persons using original spare parts should carry out repairs. Failure to do this may result in considerable danger to the user and invalidation of warranty.

### 33. Caution! Motor may become hot during use

- It is normal for motors on some machines to become hot to the touch during use. Avoid touching the motor directly when in use.

## 3. Additional Health & Safety for Belt & Disc Sanders

### Safe Operation

#### 1. Familiarise yourself with the machine

- Machining operations using belt or disc sanders have a history of serious accidents. Most accidents with sanders are caused by the work piece being thrown from the sanding surface or by loose clothing or fingers being caught between the moving parts of the machine.
- The machine is designed for sanding wood and composite board (plywood, MDF etc.). It should not be used for sanding any other materials.

#### 2. Before switching the machine 'ON':

- Ensure that the table / work support is secure and that any fixings which allow adjustment are fully tightened.
- Check the condition of the sanding disc / belt for damage or fraying. Defective discs and belts should be replaced immediately.
- Make sure there are no nails or foreign objects in the part of the work piece to be sanded.
- Plan your work to avoid throwbacks – the work piece can catch on the moving sanding surface and may be torn from the hand.

#### 3. Whilst machining:

- Always apply the work piece to the table / work support before it makes contact with the sanding surface.
- Use extra caution when working with large, very small or irregularly shaped work pieces.

- When sanding irregularly shaped work pieces, plan your work support so it will not slip and be pulled from your hands.
- Never use the machine to finish pieces too small to hold by hand.
- Do not apply excessive force to the work piece. Press the work piece against the sanding surface only hard enough to let it sand without slowing the machine or binding.
- Keep fingers away from the area between the table / work support and sanding surface.
- When using a disc sander, always press the work piece against the side of the disc that is moving down towards the table. Sanding against the side coming up from under the table could damage the work by making it "chatter", or tear the work from the hands and throw it.
- Keep your face and body to one side, out of line of a possible throwback.

4. This machine falls under the scope of the 'Health & Safety at Work etc. Act 1974', and the 'Provision & Use of Work Equipment Regulations 1998'. In addition the elimination or control of risks from wood dust is included in the above regulations and the 'Control of Substances Hazardous to Health (COSHH) Regulations 2002'. We recommend that you study and follow these regulations.

Further guidance is available from The Health & Safety Executive and their website [www.hse.gov.uk](http://www.hse.gov.uk).

# 4. Record Power Guarantee

“**Products**” means the Products sold by Record Power subject to these terms and conditions;

“**Record Power**” is Record Power Limited, whose company registration number is 4804158 and registered office address is Centenary House, 11 Midland Way, Barlborough Links, Chesterfield, Derbyshire S43 4XA and sells through a network of Authorised Dealers;

“**Authorised Distributor**” is the nominated importer for your region who will generally sell through a network of Authorised Dealers. Details of Authorised Distributors for specific countries can be found in the Product manual or at [www.recordpower.info](http://www.recordpower.info);

“**Authorised Dealer**” is a retailer or business authorised to sell Record Power Products to end users.

## 1 Guarantee

- 1.1 Record Power guarantees that for a period of 5 years from the date of purchase the components of qualifying Products (see clauses 1.2.1 to 1.2.9) will be free from defects caused by faulty construction or manufacture.
- 1.2 During this period Record Power, its Authorised Distributor or Authorised Dealer will repair or replace free of charge any parts which are proved to be faulty in accordance with paragraphs 1.1 above provided that:
  - 1.2.1 you follow the claims procedure set out in clause 2 below;
  - 1.2.2 Record Power, our Authorised Distributor or Authorised Dealer are given a reasonable opportunity after receiving notice of the claim to examine the Product;
  - 1.2.3 if asked to do so by Record Power, its Authorised Distributor or Authorised Dealer, you return the Product, at your own cost, to Record Power’s premises or other approved premises such as those of the Authorised Distributor or supplying Authorised Dealer, for the examination to take place;
  - 1.2.4 the fault in question is not caused by industrial use, accidental damage, fair wear and tear, wilful damage, neglect, incorrect electrical connection, abnormal working conditions, failure to follow our instructions, misuse, or alteration or repair of the Product without our approval;
  - 1.2.5 the Product has been used in a domestic environment only;
  - 1.2.6 the fault does not relate to consumable Products such as blades, bearings, drive belts or other wearing parts which can reasonably be expected to wear at different rates depending on usage (for full details contact Record Power or your local Authorised Distributor);
  - 1.2.7 the Product has not been used for hire purposes, by you or by a previous owner;
  - 1.2.8 the Product has been purchased by you as the guarantee is not transferable from a private sale.
  - 1.2.9 where the Product has been purchased from a retailer, the 5 year guarantee is transferable and begins on the date of the first purchase of the Product and in the event of a claim under this guarantee proof of the original purchase date will be required to validate the warranty period.

## 2 Claims Procedure

- 2.1 In the first instance please contact the Authorised Dealer who supplied the Product to you. In our experience many initial problems with machines that are thought to be due to faulty parts are actually solved by correct setting up or adjustment of the machines. A good Authorised Dealer should be able to resolve the majority of these issues much more quickly than processing a claim under the guarantee.
- 2.2 Any damage to the Product resulting in a potential claim under the guarantee must be reported to the Authorised Dealer from which it was purchased within 48 hours of receipt.
- 2.3 If the Authorised Dealer who supplied the Product to you has been unable to satisfy your query, any claim made under this Guarantee should be made directly to Record Power or its Authorised Distributor (for details of the Authorised Distributor in your country please see your Product manual or check [www.recordpower.info](http://www.recordpower.info) for details). The claim itself should be made in a letter setting out the date and place of purchase, and giving a brief explanation of the problem which has led to the claim. This letter should then be sent with proof of the purchase date (preferably a receipt) to Record Power or its Authorised Distributor. If you include a phone number or email address this will help to speed up your claim.
- 2.4 Please note that it is essential that the letter of claim reaches Record Power or its Authorised Distributor on the last day of this Guarantee at the latest. Late claims will not be considered.

## 3 Limitation of Liability

- 3.1 We only supply Products for domestic and private use. You agree not to use the Product for any commercial, business or re-sale purposes and we have no liability to you for any loss of profit, loss of business, business interruption or loss of business opportunity.
- 3.2 This Guarantee does not confer any rights other than those expressly set out above and does not cover any claims for consequential loss or damage. This Guarantee is offered as an extra benefit and does not affect your statutory rights as a consumer.

## 4 Notice

This Guarantee applies to all Products purchased from an Authorised Dealer of Record Power within the United Kingdom of Great Britain and Northern Ireland. Terms of Guarantee may vary in other countries – please check with the Authorised Distributor in your country (details of the Authorised Distributor for your country can be found in the manual or at [www.recordpower.info](http://www.recordpower.info)).

# 5. Machine Specification

<b>Motor:</b>	230 V / 50 Hz / 1 hp / 800 W
<b>Full load current:</b>	6.7 A
<b>Belt Size:</b>	152 x 1219 mm
<b>Disc Size:</b>	254 mm
<b>Disc Worktable Tilt:</b>	0 - 45°
<b>Belt Tilt:</b>	0 - 90°
<b>Disc Speed:</b>	1400 min-1
<b>Belt Speed:</b>	517 m/min
<b>Weight:</b>	47 kg
<b>Noise Emission:</b>	Sound pressure level (unloaded): 78 dB(A) Sound pressure level (loaded): 84.2 dB(A)

# 6. Unpacking and Checking Contents

This machine is shipped complete in one carton. Separate all parts from packing materials and check each item with illustration and bag of loose parts.

**Note:** Make certain all items are accounted for, before discarding any packing material.

**Warning:** To avoid injury, if any parts are missing, do not attempt to assemble the belt and disc sander, unplug the power cord until the missing parts are obtained and installed correctly.

**Warning:** For your own safety, never connect plug to power source outlet, or switch on until all assembly steps are complete and until you have read and understood the entire Owner's manual.

For assembly you will need (not included):



Standard Screwdriver

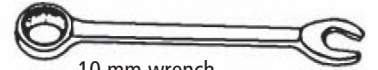

10 mm wrench



Phillips Screwdriver

Item	Description	Quantity
A	Belt & disc sander assembly	1
B	Owner's manual	1
C	Table	1
D	Sanding disc	1
E	Mount, support table	2
F	Table support with scale	2
G	Work table for belt	1
H	Bag of loose parts	1
Contains:		
	Hex 'L' wrench 3 mm	1
	Hex 'L' wrench 6 mm	1
	Sunk head screw, M6 x 16	1
	Pan head screw, M6 x 16	2
	Hex nut, M6	4
	External lock washer 6 mm	4
	Wing nut, 6 mm	8
	Flat washer, 6 mm	2

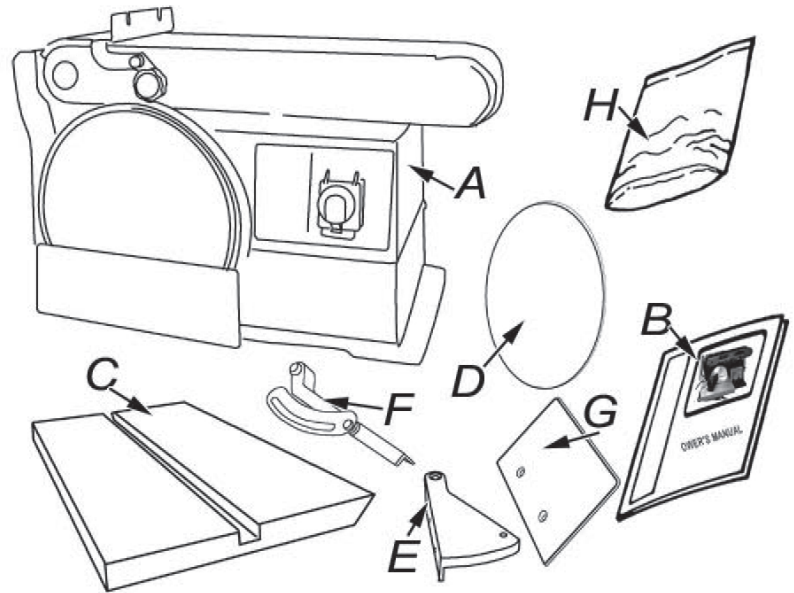

# 7. Assembly Instructions

## Mounting Belt and Disc Sander to Workbench

If belt and disc sander is to be used in a permanent location, it should be fastened securely to a firm supporting surface such as workbench. If mounting to a workbench, holes should be drilled through supporting surface of the workbench using dimensions shown in **Fig 7.1**.

1. The unit should be bolted securely using M8 screws and hex nuts (not included). The screw length should be 50 mm plus the thickness of the bench top.
2. Locate the mounting holes, **Fig 7.2**, and mark the holes through the workbench.
3. Drill 4-10 mm diameter holes through workbench.
4. Place belt and disc sander on workbench aligning holes on base with holes drilled in workbench.
5. Insert 4 M8 screws and tighten hex nuts.

**NOTE:** The mounting holes marked (A) **Fig 7.1** should be a maximum of 140 mm from the front edge of the work bench.



**If mounting the machine to the optional floor stand, Please refer to section 17.**



**Caution:** To avoid injury from tool movement, the supporting surface where the belt and disc sander is mounted should be examined carefully after mounting to ensure that no movement during use can result. If any movement occurs, secure the workbench or supporting surface before resuming operation of the belt and disc sander.

## Installing Sander Disc and Guard

1. Remove the backing from the self-adhesive sanding disc. Align perimeter of disc with plate and press disc firmly into position all the way around, **Fig 7.3**.
2. Locate disc guard and two pan head screws M4 x 40, from the loose parts bag.
3. Position disc guard against lower 1/3 disc aligning holes, **Fig 7.3**.
4. Using a Phillips screwdriver, fasten the pan head screw securely applying slight pressure to thread the holes.

## Installing Work Table

1. Place the work table for the belt on the work support.
2. Insert 2 counter sunk head screws through the work table and the work support slot, **Fig 7.4**.
3. Put a 6 mm washer and a wing nut on the screw and tighten.

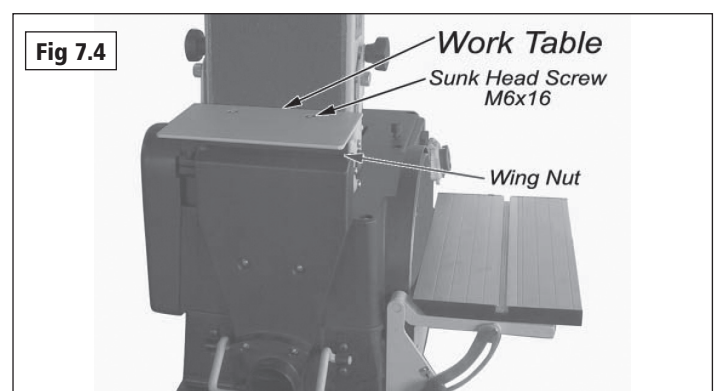
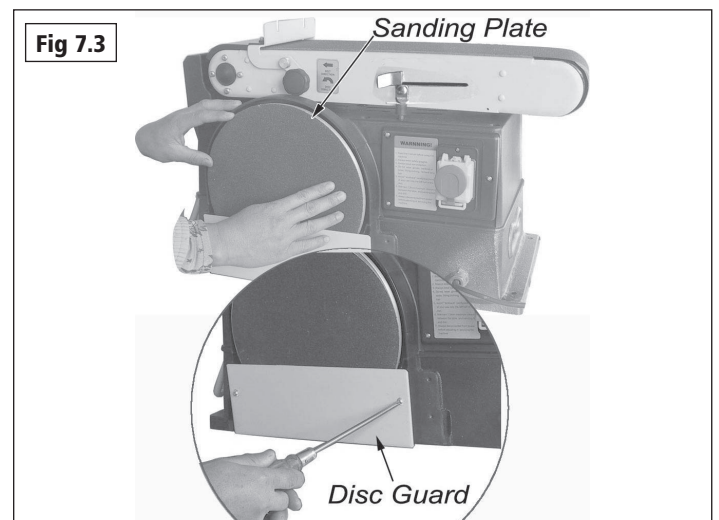
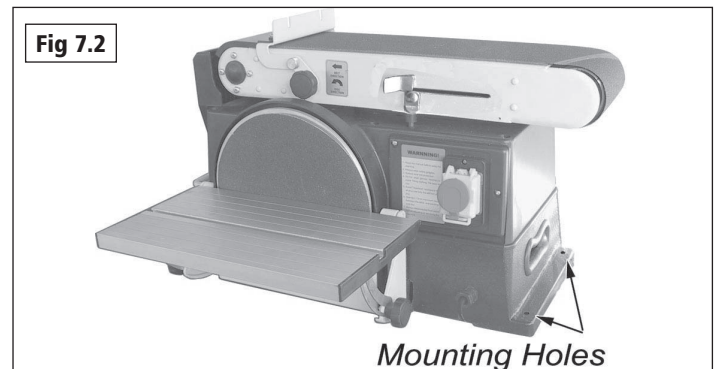
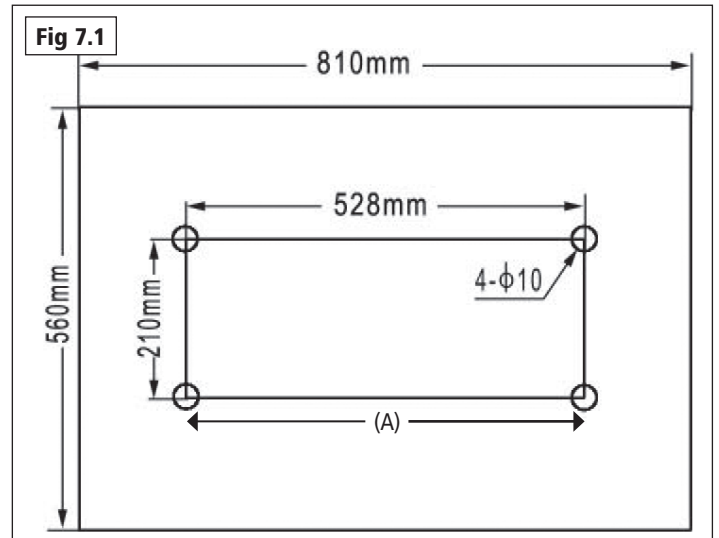



# 7. Assembly Instructions - cont.

## Installing Table

### Fig 7.5.

1. Use 4 M6 x 16 pan head screws to fasten both table support mounts onto the front of the machine.
2. Place the support table with scale onto the table support mount.
3. Put a 6 mm flat washer on the table lock knob, and place the knob into the tilt scale plate and mount and tighten by hand.
4. Place the table onto the table support, align the 4 screws which are pre-assembled under the table with the holes of the table support.
5. Put the external lock washer and hex nut onto the screws and tighten.
6. Adjust the table and re-tighten the table lock knobs.



**Warning:** To avoid trapping the work or fingers between the table and sanding surface, the table edge should be a maximum of 3 mm from sanding surface.

7. Loosen the 4 M6 hex nuts under the table.
8. Using a suitable spacer, for example a 3 mm thick piece of card or 3 mm diameter drill bit, hold the table against the spacer and tighten the 4 M6 hex nuts, **Fig 7.6.**

## Squaring Table Assembly



**Warning:** To avoid injury from accidental starting, make sure the machine is unplugged before aligning.

1. Using a combination square, check the angle of work table with the disc.  
Note: The combination square must be true, **Fig 7.7.**
2. If the table is not at 90° to the disc, loosen table lock knob screw and adjust the table.
3. Adjust work table square to the disc and re-tighten table lock knob.
4. Adjust the pointer to zero mark on the scale plate.

Fig 7.5

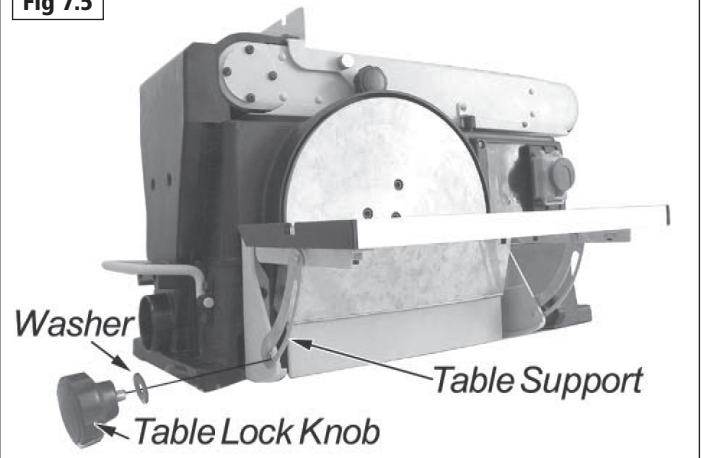

Fig 7.6

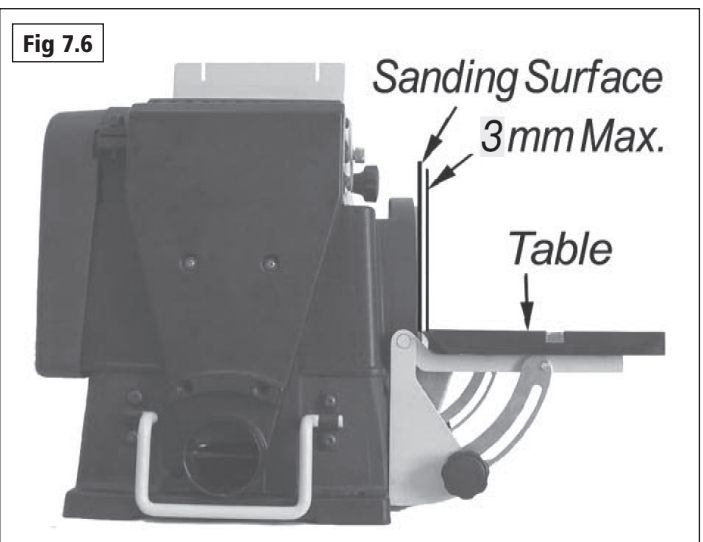
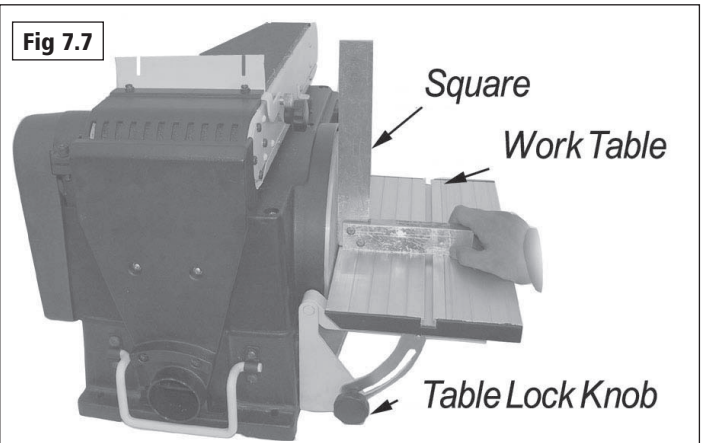

Fig 7.7



# 7. Assembly Instructions - cont.

## Installation of the Sanding Belt, Tensioning & Tracking



**Warning:** To avoid injury from accidental starting, make sure the machine is unplugged before aligning. On the smooth side of the sanding belt, you will find a directional arrow. The sanding belt must run in the direction of this arrow so that the spliced joint does not come apart.

1. Remove two lock knobs of the sander belt work support, **Fig 7.8**.
2. Remove the work support lock pin, **Fig 7.9**.
3. Remove the work support, **Fig 7.10**.
4. Loosen the hex head socket screw, **Fig 7.11**, to allow the belt bed to be raised.
5. Slide tension lever to the left to release the belt tension, **Fig 7.12**.
6. Place the sanding belt over the drums with the direction arrow pointing as shown in **Fig 7.13**. Make sure the belt is centred on both drums.
7. Slide tension lever to the right to apply belt tension, **Fig 7.12**.
8. Tighten hex socket screw when bed is in desired position.
9. Reinstall the work support.
10. Rotate the belt by hand in the direction of the arrow. If the belt tends to slide off the idler drum or drive drum, adjust the belt using the tracking knob, **Fig 7.12** until the belt runs centrally on both drums.
11. If the sanding belt moves toward the disc, turn the tracking knob clockwise 1/4 turn.
12. If the sanding belt moves away from the disc, turn the tracking knob anti-clockwise 1/4 turn.

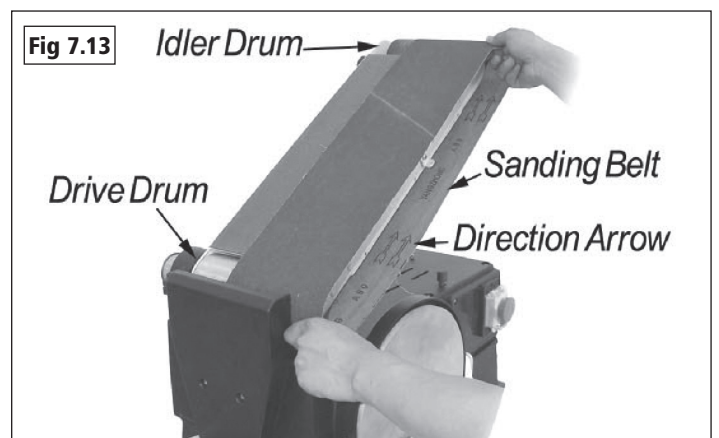
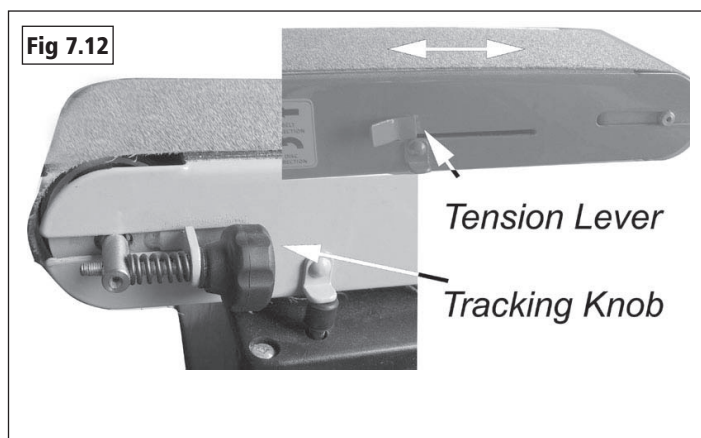
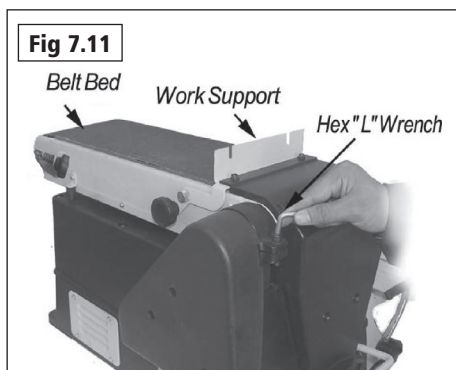
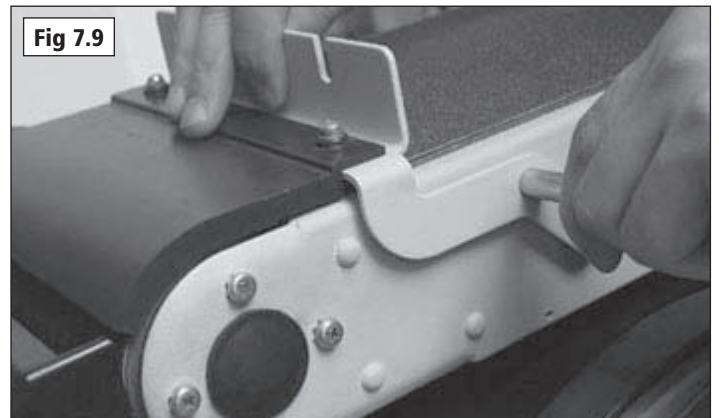

# 8. Getting To Know Your Belt and Disc Sander



**Warning:** To avoid injury from accidental start, remove the plug from power source outlet before making any adjustments.

**Fig 8.1**

1. Hex socket head screw. Loosening screw allows belt bed to raise to the vertical position.
2. Tracking knob. Turning knob anti-clockwise causes sanding belt to move towards the disc; otherwise to move away from the disc
3. Sanding belt.
4. Tension lever. Sliding lever to the right releases the sanding belt tension; sliding lever to the left applies belt tension.
5. Work support hex screw.
6. Work support. Supports the workpiece on the sanding belt.
7. Base.
8. Belt bed.
9. Mounting holes.
10. No-volt switch
11. Sanding Disc.
12. Sanding paper.
13. Work table assembly.

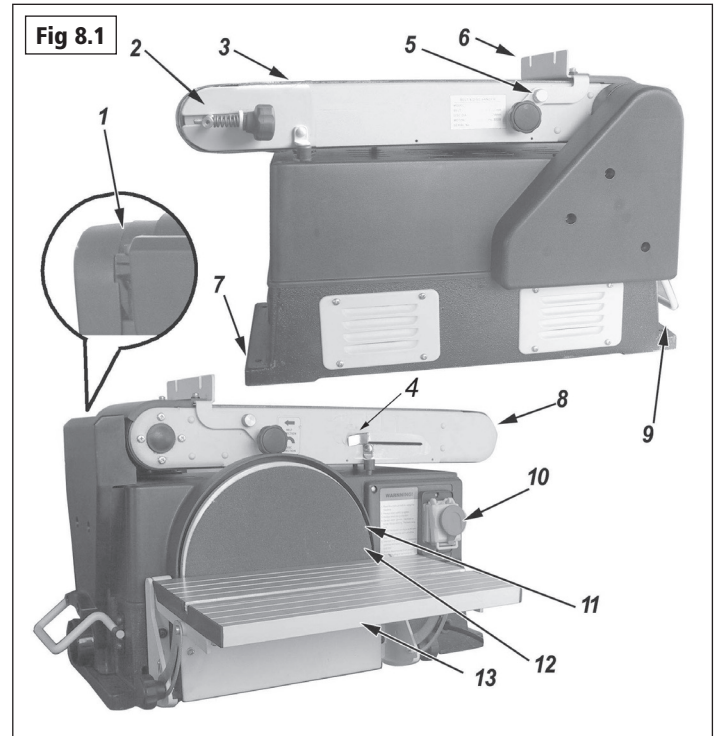

# 9. No Volt Switch

**Note:**

The no-volt switch has no-volt release and emergency stop feature. This feature is intended to prevent the unauthorised starting.

1. To turn machine on, raise the emergency stop cover up, and push the green button (with "I" symbol) about 1 second.

2. To turn machine off, just push the emergency stop cover down. The emergency stop cover can be locked in the stop position.
3. Any time when you need to stop the machine, push the emergency stop cover down.

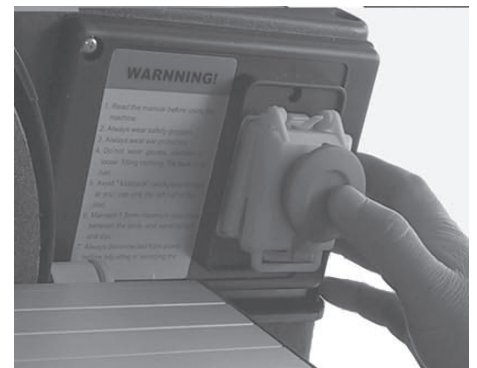
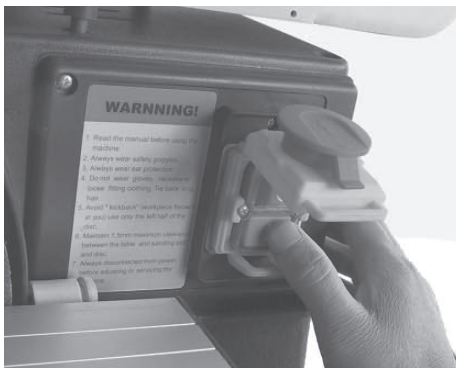

# 10. Basic Operation

## Before Using the Sander



**Warning: To avoid mistakes that could cause serious injury, do not plug the sander in until the following steps are completed.**

1. Assembly and alignment.
2. Learn the use and function of no-volt switch, work support, belt tracking knob, belt tension lever, work table and work table tilt lock knob.
3. Review and understand all safety instructions and operating procedures in this manual.
4. Review the maintenance procedure for this sander.

## Before Each Use Inspect your Sander

- Check the gaps between the work surface and the sanding areas are no more than 3 mm and adjust accordingly.
- Do not use sanding belts narrower than 6". Narrower belts uncover parts that could trap your fingers.

To avoid injury from jams, slips or thrown pieces:

- Adjust any work support to clear the sanding surface by no more than 3 mm. When checking clearance between the belt and work support, press the belt against the metal beneath it.

## Inspect the Workpiece



**Caution: Make sure there are no nails or foreign objects in the part of the work piece to be sanded.**

- When finishing on the disc, always press the workpiece against the side of the disc moving downwards towards the table. Sanding against the side coming up from under the table could damage the work by making it 'chatter', or tear the work from your hands and throw it.

## In the Event of a Blockage or if the Machine Stalls

If the machine stalls due to the work piece or sanding belt becoming trapped, switch the machine off immediately by pressing the red button on the switch marked 'O'.

Locate and rectify the source of the blockage. If the sanding belt has become trapped, it may be necessary to cut the belt in order to remove it from the machine. Replace the belt as necessary and track it correctly by following the procedure set out in section 7 of this manual.

Check that the belt can be turned freely by hand before attempting to re-start the machine. Re-start the machine by pressing the green button on the switch marked 'I'.

## Re-Starting After a Power Failure

The machine is fitted with a no volt release (NVR) switch to protect the user from automatic re-starting after a power failure.

In the event of a power failure, first locate and rectify the source of the failure. If the fault is within the power circuit of the workshop, there may be an underlying cause (circuit overload etc.) that should be investigated by a qualified electrician, before attempting to restore the power source.

Once the power is restored, re-start the machine by pressing the green button marked 'I' on the switch.

# 10. Basic Operation - cont.

## Bevel Sanding

The work table can be tilted from 0° to 45° for bevel sanding. Loosen the table lock knob and tilt the worktable to desired angle as shown, **Fig 10.1**. Re-tighten table lock knob.



**Warning:** To avoid trapping the work or fingers between the table and sanding surface, the table should be repositioned on the table support to retain a maximum of 3 mm distance between sanding surface and table, **Fig 10.2**.

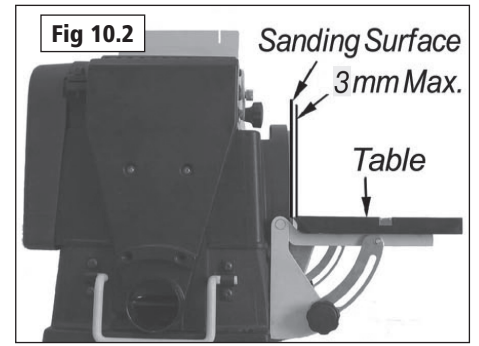
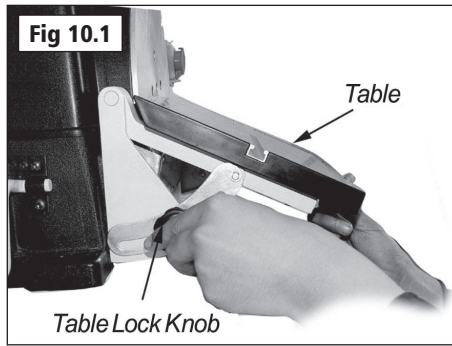

## Positioning the Belt Bed

A bed locking hex socket head screw locks the belt bed in a vertical or horizontal position. To adjust the vertical position:

1. Loosen the hex socket head locking screw using a 6 mm hex wrench, **Fig 10.3**.
2. Position belt bed vertically as shown in **Fig 10.4** and tighten the hex socket head locking screw.

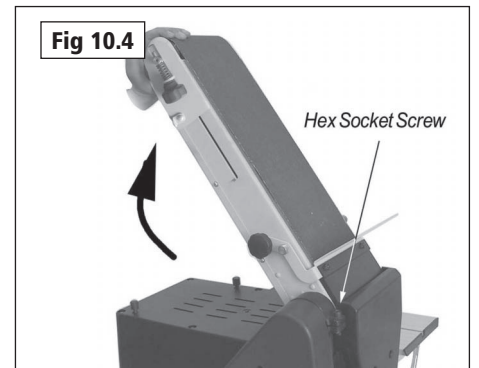
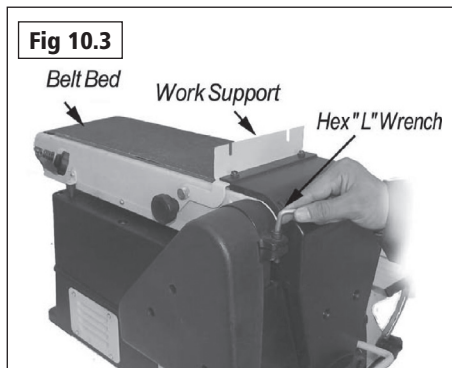

## Surface Sanding On The Belt



**Warning:** To avoid injury from slips, jams or thrown pieces, adjust the work support to clear the sanding surface by no more than 3 mm.

When checking clearance between the belt and work support, press the belt flat against the metal beneath it.

Hold the workpiece firmly with both hands, keeping fingers away from the sanding belt, **Fig 10.5**.

Keep the end butted against the backstop and move the work evenly across the sanding belt. Use extra caution when sanding very thin pieces.

For sanding long pieces, remove the work support.

Apply only enough pressure to allow the sanding belt to remove material.

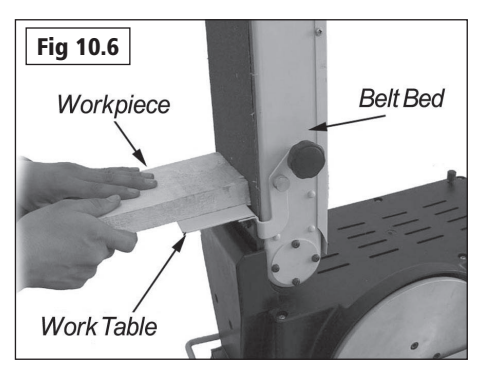
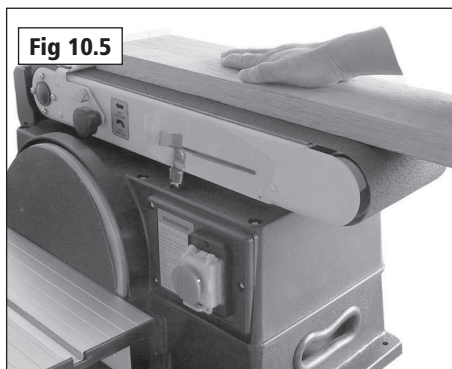

## End Sanding On The Belt

It is more convenient to sand the ends of long workpieces with the sanding belt in a vertical position.

If necessary, install the worktable assembly.

Move the work evenly across the sanding belt, **Fig 10.6**.

# 10. Basic Operation - cont.

## Sanding Curved Edges

Always sand inside curves on the idler drum as shown in Fig 10.7.



**Warning:** Never attempt to sand the ends of a workpiece on the idler drum, applying the end of the workpiece to the idler drum could cause the workpiece to fly up and result in an injury.

Always sand outside curves on the left side of centre on the sanding disc as shown in Fig 10.8.

**Warning:** Applying the workpiece to the right hand side of the disc can cause workpiece to fly up (kickback) and result in injury.

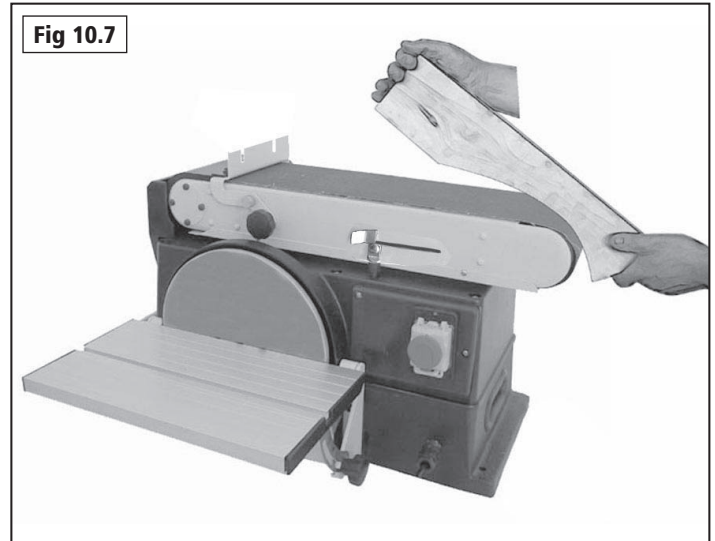

## Sanding Small End Surfaces on the Sanding Disc



**Note:** Use of a mitre fence is recommended for this operation. Always move the work across the left side of centre on the sanding disc face as shown, Fig 10.8.



**Warning:** For your own safety, remove the plug from power source outlet before adjusting the sander.

Use a combination square to square the mitre fence to the face of the disc. The combination square must be true. If it is not square, loosen the mitre gauge knob and move the mitre gauge, tighten the knob securely, Fig 10.9.

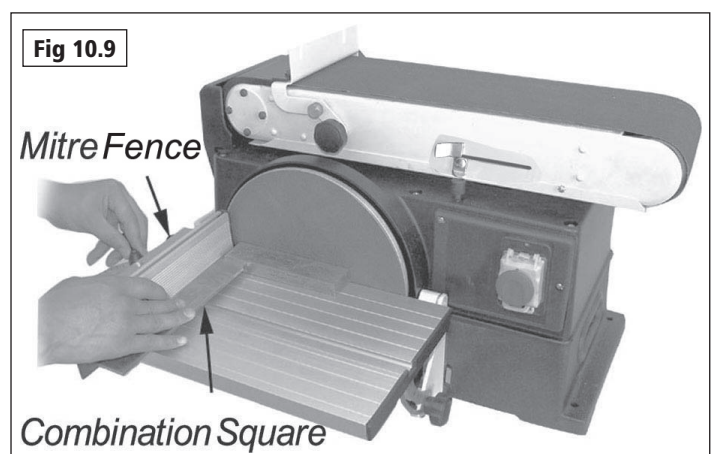
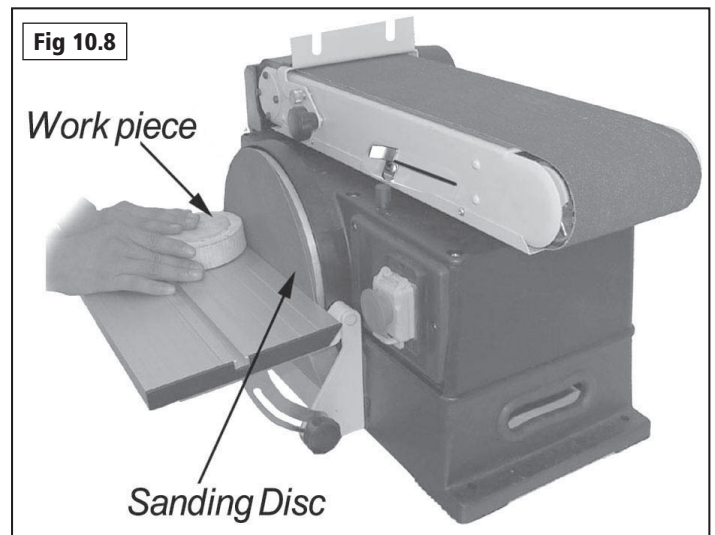

# 11. Maintenance



**Warning:** For your safety, remove the plug from power source outlet before adjusting or maintaining the belt and disc sander.

Frequently blow out or vacuum out any dust that may accumulate inside the motor. A coat of automobile-type wax applied to the worktable will make it easier to feed the work while finishing.

Do not apply wax to the abrasive belt table because the belt could pick up the wax and deposit it on the pulleys, causing the belt to slip.

## Lubrication

The ball bearings in this machine are packed with grease during manufacture. They require no further lubrication.

## Changing the Drive Belt

1. Using a Phillips screwdriver remove 3 pan head screws located in the cover, **Fig 11.1**.
2. Remove the cover.
3. Loosen 4-M8 hex head screw with wrench to allow pulley to shift enough to place belt around them. Place belt around motor pulley and drive pulley as shown.
4. Adjust tension of the belt by putting a wrench in adjusting gap. Push up on wrench to tighten tension between pulleys, **Fig 11.2**.
5. Tighten 4-M8 hex head screws careful.
6. Test belt tension by placing fingers on either side of the belt and squeeze. There should be about a 6mm give on the belt, **Fig 11.3**.

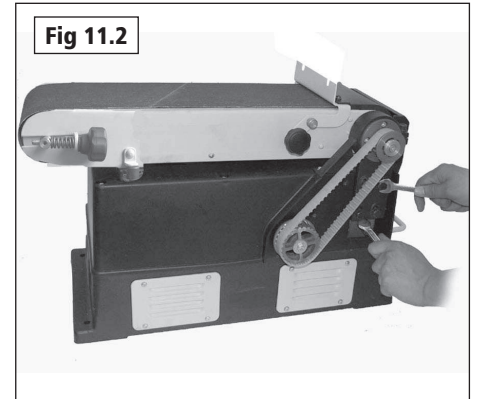
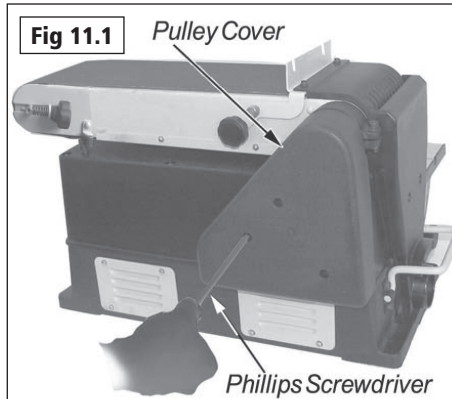

**Please note: Excessive tension on the pulley belt may cause increased noise and overload the motor. Excessive movement on pulley belt may cause the belt to fail prematurely.**

7. Locate the pulley cover and position inside the recessed edges of pulley housing.
8. Using a Phillips screwdriver, reinstall and tighten 3 pan head screws.

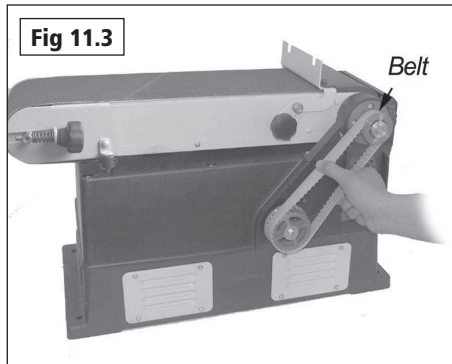

# 12. Troubleshooting

PROBLEM	PROBABLE CAUSE	REMEDY
Sander does not operate.	Not plugged into power outlet. Power switch defective. Motor or wiring problem.	Plug into power outlet. Replace switch. Have qualified electrician carry out repair.
Motor slows when sanding.	Timing belt too tight. Applying too much pressure.	Decrease tension. Apply less pressure to the workpiece when sanding.
Wood burns while sanding.	Sanding disc or belt is loaded with debris.	Clean or replace disc or belt.
Sander makes excessive noise.	Timing belt too tight. Bearing worn.	Decrease tension. Replace bearing.

# 13. Dust Extraction

## The Importance of Dust Extraction

Suitable dust extraction is essential to avoid the possibility of serious health problems related to wood dust. It is also necessary in order to ensure the waste producing machine performs safely and effectively. Some woods are extremely toxic and in addition to suitable dust extraction machines it is recommended that PPE such as respirators are also used.

## Record Power Dust Extraction Machines

Below is a summary of the Record Power range. Please visit your local stockist or go online for full details.

### CGV286 CamVac Series Compact Extractor

36 litre capacity, 1 kW single or twin motor, 0.5 micron filtration. Includes hose.

### CGV286-3-WALL CamVac Series Wall Mounted Extractor

150 litre capacity, twin motor, 0.5 micron filtration. Includes hose.

### CGV336 CamVac Series Medium Extractor

55 litre capacity, 1 kW single or twin motor, 0.5 micron filtration. Includes hose.

### CGV386 CamVac Series Large Extractor

90 litre capacity, 1 kW twin or triple motor, 0.5 micron filtration. Includes hose.

### CGV486 CamVac Series Heavy Duty Extractor

200 litre capacity, 1 kW triple motor, 0.5 micron filtration. Includes hose.

### DX1000 Fine Filter 45 Litre Extractor

45 litre capacity, 1 kW motor, 0.5 micron filtration. Includes hose. Includes hose.

### AC400 2 Stage Air filter with Remote, 3 speeds and Time Delay

Collects airborne dust, 1 micron filtration.

	Bandsaws	Table Saws	Planer Thicknessers	Lathes	Sanding Machines	Dust Extraction Systems	Airborne Dust Collection
DX1000	✓	✓	✓	✓	✓		
CGV286	✓	✓	✓	✓	✓		
CGV286-3-WALL	✓	✓	✓	✓	✓	✓	
CGV336	✓	✓	✓	✓	✓		
CGV386	✓	✓	✓	✓	✓	✓	
CGV486	✓	✓	✓	✓	✓	✓	
AC400							✓



# 14. Electrical Connection & Wiring Diagram

Machines supplied for use in the UK are fitted with a 3 pin plug conforming to BS1363, fitted with a fuse conforming to BS1362 and appropriate to the current rating of the machine.

Machines supplied for use in other countries within the European Union are fitted with a 2 pin Schuko plug conforming to CEE 7/7.

Machines supplied for use in Australia & New Zealand are fitted with a 3 pin plug conforming to AS/NZS3112.

In all cases, if the original plug or connector has to be replaced for any reason, the wires within the mains power cable are colour coded as follows:

## 230 V (Single Phase)

Brown: Live (L)  
 Blue: Neutral (N)  
 Green and Yellow: Earth (E)

The wire coloured brown must always be connected to the terminal marked 'L' or coloured red.

The wire coloured blue must always be connected to the terminal marked 'N' or coloured black.

The wire coloured green and yellow must always be connected to the terminal marked 'E' or with the earth symbol:



or coloured green / green and yellow.

It is important that the machine is effectively earthed. Some machines will be clearly marked with the double insulated logo:



In this case there will not be an earth wire within the circuit.

In the case of the BS1363 plug for use in the UK, always ensure that it is fitted with a fuse conforming to BS1362 appropriate to the rating of the

machine. If replacing the original fuse, always fit a fuse of equivalent rating to the original. Never fit a fuse of a higher rating than the original. Never modify the fuse or fuse holder to accept fuses of a different type or size.

Where the current rating of the machine exceeds 13 A at 230 V, or if the machine is designated for use on a 400 V 3 phase supply a connector conforming to BS4343 (CEE17 / IEC60309) will be used.

230 V machines will be fitted with a blue 3 pin connector. The wiring for this type of this connector will be the same as shown above.

400 V, 3 phase machines will be fitted with a red 4 or 5 pin connector. The wiring for this type of connector is as shown below:

## 400 V (3 phase)

Brown: Live (L1)  
 Black: Live (L2)  
 Grey: Live (L3)  
 Blue: Neutral (N)  
 Green and Yellow: Earth (E)

The wire coloured brown must always be connected to the terminal marked 'L1'.

The wire coloured black must always be fitted to the terminal marked 'L2'.

The wire coloured grey must always be connected to the terminal marked 'L3'.

The wire coloured blue must always be connected to the terminal marked 'N' or coloured black.

The wire coloured green and yellow must always be connected to the terminal marked 'E' or with the earth symbol

If in doubt about the connection of the electrical supply, always consult a qualified electrician.

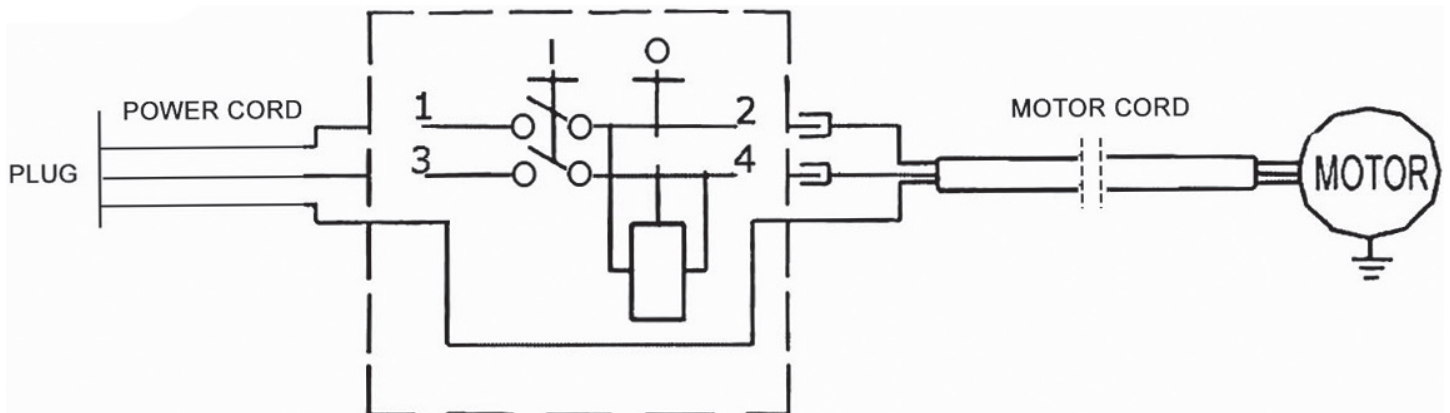

# 15. Exploded Diagram & Parts List

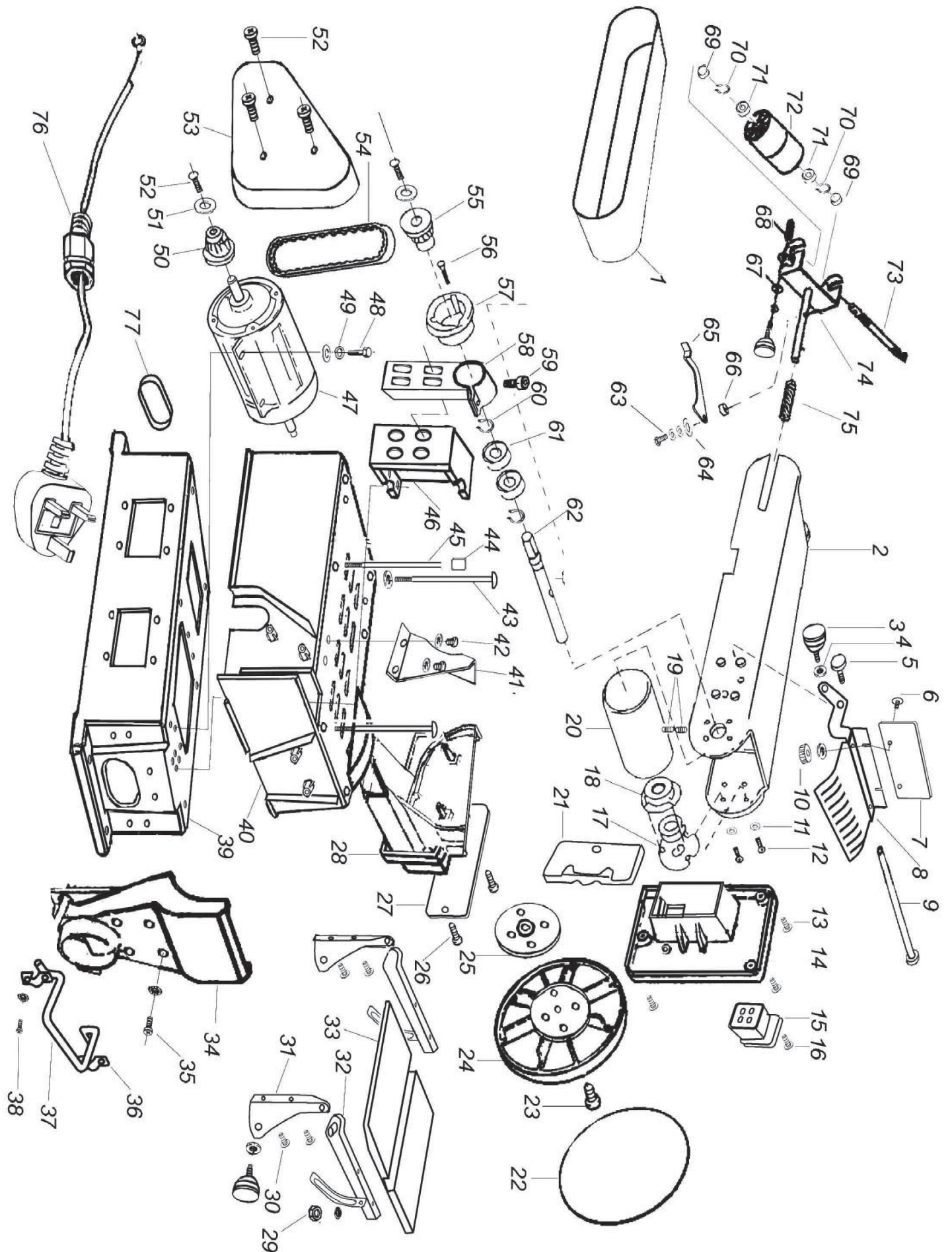

# 15. Exploded Diagram & Parts List

1	Sanding belt 152 x 1219 mm	40	Motor cover
2	Bed	41	Lower safety guard
3	Knob	42	Pan head screw M5 x 8
4	Washer	43	Thread M6 x 145
5	Wing screw	44	Rubber sleeve
6	Sunk head screw M6 x 16	45	Support stem
7	Work table for belt	46	Lock base sander belt
8	Work support, sander belt	47	Motor
9	Lock pin, work support	48	Hex head screw
10	Wing nut M6	49	Lock washer
11	Security washer 5 mm	50	Drive pulley
12	Pan head Screw M5 x 8	51	Countersink washer
13	Pan head screw M5 x 16	52	Flat cross screw M5 x 10
14	Switch housing	53	Pulley cover
15	No-volt switch	54	Timing belt
16	Tapping screw	55	Drive pulley
17	Bearing spacer with bearing	56	Flat head screw M5 x 25
18	Bearing cap	57	Bearing support
19	Socket head screw M8 x 10	58	Lock plate for sanding bed
20	Drive drum	59	Hex socket cap screw M8 x 25
21	Cover, switch housing	60	Retaining ring 15mm
22	250 mm sanding disc	61	Ball bearing
23	Screw-pan cross M6 x 12	62	Drive shaft
24	Disc	63	Pan head screw M5 x 16
25	Support, sanding disc	64	Rubber washer
26	Tapping screw M4 x 12	65	Tension lever
27	Disc guard	66	Lever spacer
28	Disc shroud	67	Rubber washer
29	Hex nut M6	68	Index spring
30	Pan head screw M6 x 16	69	Rubber bushing
31	Mount, table support	70	Retaining ring 12 mm
32	Table support	71	Ball bearing
33	Table	72	Idler drum
34	Dust collector	73	Idler shaft
35	Pan head screw M5 x 16	74	Drum guide
36	Clamp handle	75	Index spring
37	Handle	76	Power cord w/plug
38	Pan head screw M5 x 16	77	"D" shape rubber bushing
39	Cast Base		

# 16. Assembly of the Optional BDS250-A Stand.



**CAUTION! The machine is heavy. Additional help or a suitable lifting device or support will be required for lifting the machine onto the stand.**

The stand comes as a self assembly unit **Fig.16.1**.

## Stand

- 1. 2 x Long mid brace supports
- 2. Short mid brace supports x2
- 3. 2 x Long top brace supports
- 4. 2 x Short top brace supports
- 5. 4 x Legs
- 6. 24 x Stand fixing nuts bolts and washers (each)
- 7. Long fixing bolts, 2 washers and 2 nuts x 4

**Fig. 16.1**

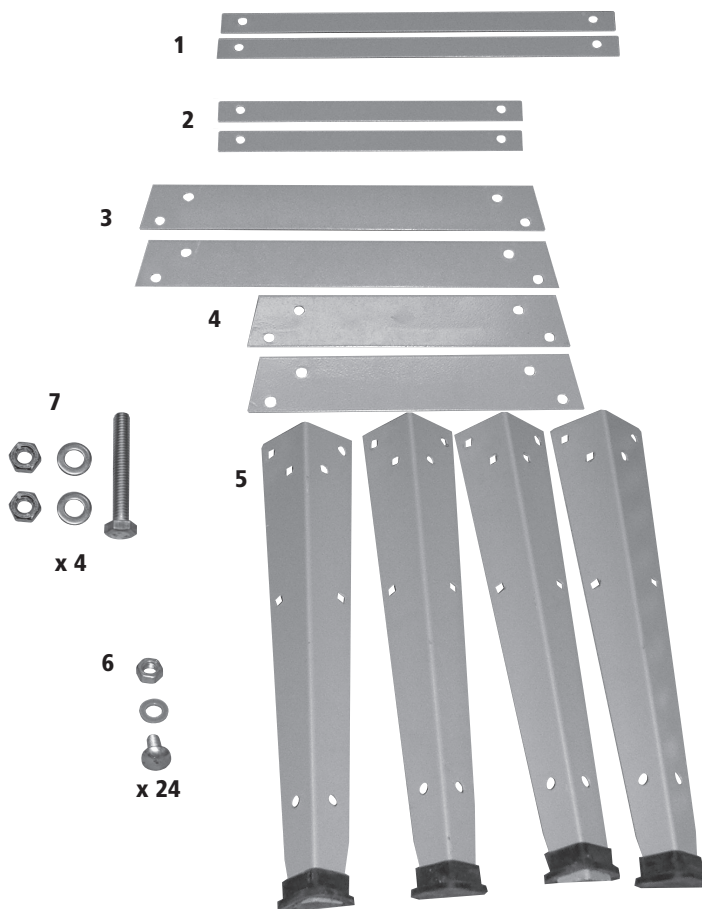

# 16. Assembly of the Optional BDS250-A Stand.



**Note:** When assembling this legstand do not fully tighten the nuts and bolts until the assembly is complete.

When fitting the optional pedal wheel kit during initial assembly of the machine, please do so before attaching the machine to the leg stand to ensure greater safety and ease of fitment.

When fitting the optional pedal wheelkit, the short mid brace support (Fig 16.7) at the front of the machine should be removed.

## 3.2 Stand Assembly

1. Locate the first leg and secure it to one of the long top brace supports using the nuts, bolts and washers supplied **Fig.16.2**.
2. In the same way, attach the second leg to the brace support **Fig.16.3**.
3. Locate the short top brace supports and fix to the legs as shown **Fig.16.4**.
4. Continue in this way until all of the legs and top brace supports have been fitted **Fig.16.5**.
5. The locating holes a third of the way down each leg are for securing the mid brace supports. Fix the long mid brace supports to the frame using the nuts, bolts and washers **Fig.16.6**.
6. Finally, fit the short and medium mid brace supports to the shorter sides **Fig.16.7** in the holes located a third of the way down the legs.

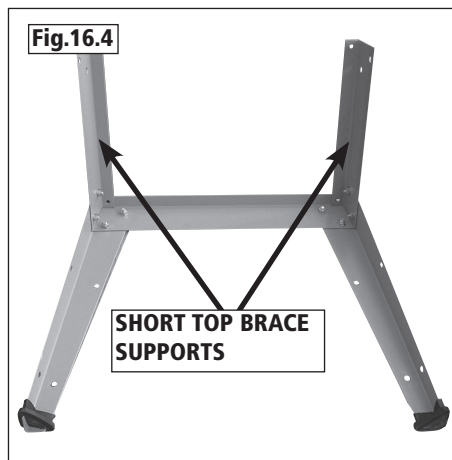
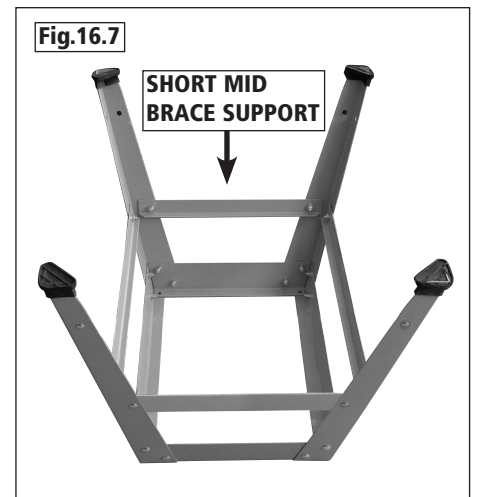
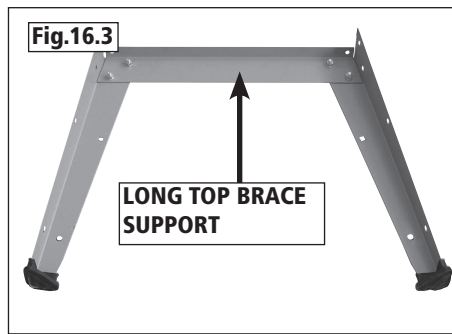
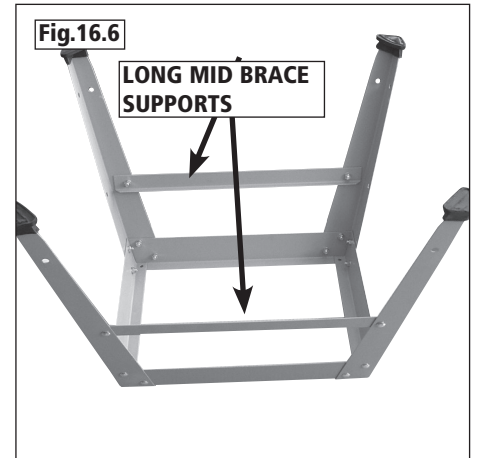
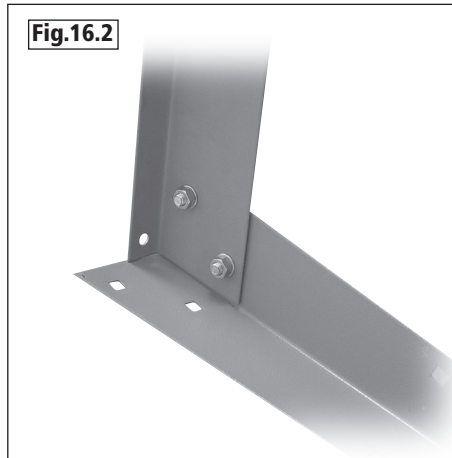

# 16. Assembly of the Optional BDS250-A Stand

1. Feed the long fixing bolts up through the stand and secure the four corners using the washers and bolts provided **Fig.16.8**. The whole stand can now be fully tightened ready for the machine to be fitted.

## 3.4 Fitting the machine to the stand



**CAUTION! The machine is heavy. Additional help or a suitable lifting device or support will be required for lifting the machine onto the stand.**

1. Lift the machine over the stand and place the long fixing bolts through the four location holes in the machine base **Fig.16.9**.

2. Secure the machine to the stand with the remaining washers and nuts **Fig.16.9**.

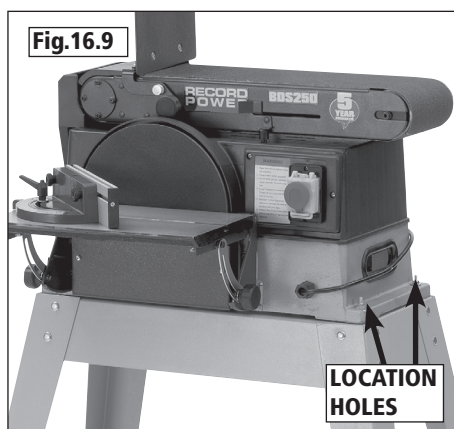
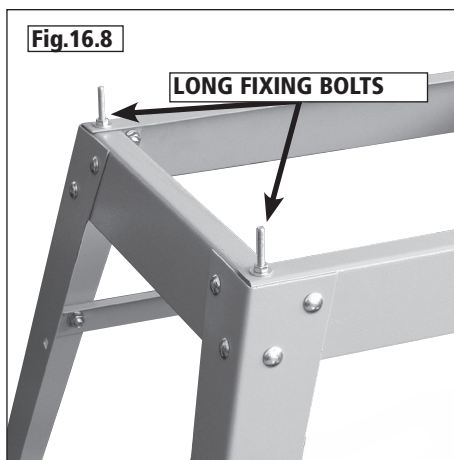

# 17. Assembly of the Optional BDS250-W Pedal Wheel Kit

Fig.17.1

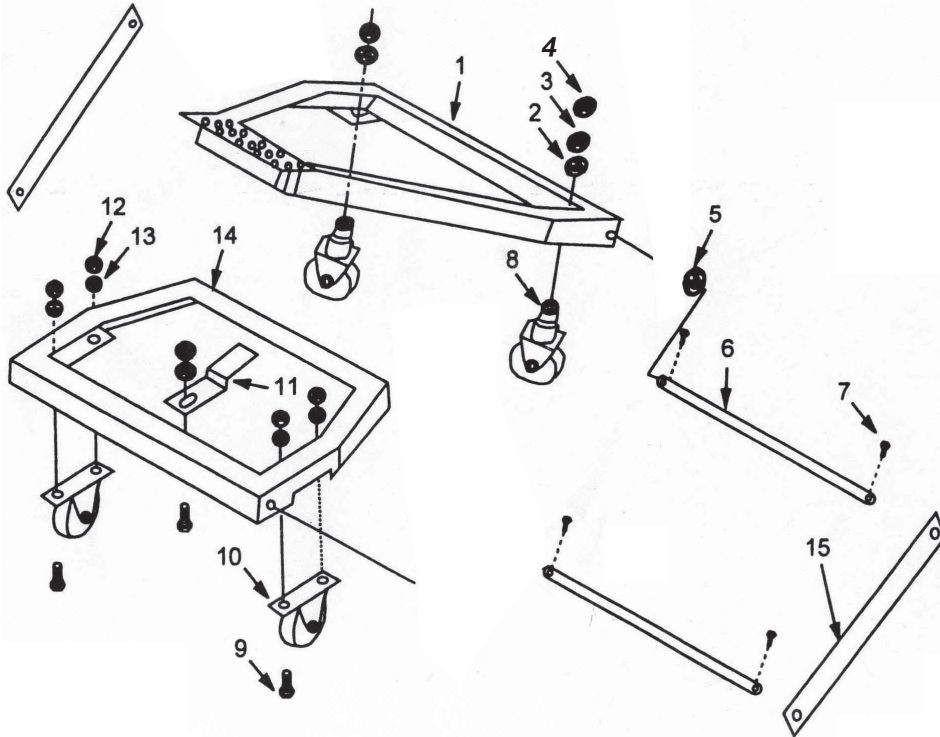

1	Pedal	1
2	Flat washer	2
3	Hex nut	2
4	Spring washer	7
5	Washer	4
6	Axle	2
7	Split pin	4
8	Rotating casters	2
9	Hex bolt	5
10	Casters	2
11	Release catch	1
12	Hex nut	5
13	Flat washer	5
14	Operating frame	1
15	Brace support bar	2



**When fitting the optional pedal wheel kit during initial assembly of the machine, please do so before attaching the machine to the leg stand to ensure greater safety and ease of fitment.**

**When fitting the optional pedal wheel kit, the short mid brace support (Fig. 17.1) at the front of the machine should be removed.**

## Assembly

1. Mount the two casters to the flattened areas on the underside of the operating frame, **Fig. 17.2**. Secure in place using the nuts bolts, washers and spring washers provided, ensuring the spring washers are placed next to the nuts.

2. Fit the release catch to the operating frame with the nuts and bolts provided, **Fig. 17.3**.

3. Fit the two rotating casters to the pedal as shown in **Fig. 17.4**. Secure in place using the nuts bolts, washers and spring washers provided, ensuring the spring washers are placed next to the nuts.

4. Feed one of the axles through the hole on one of the brace support bars, **Fig. 17.5**, and secure using one of the pins and washers provided, **Fig. 17.6**.

5. Feed the axle through the fixing holes on both of the rear legs of the stand and pedal, **Fig. 17.7**. The rear side of the machine is that which is closest to the sanding disc, see **Fig. 17.8**.

6. Repeat this process at the opposite side ensuring that both sides of the axle have been secured with the fixing pins and washers and that both sides of the pedal are fixed. It should now be secure between the legs.

7. Feed the second axle through the holes in the brace support bars, front legs of the stand and operating frame. Secure using fixing pins and washers, **Fig. 17.9**.

8. Repeat this process at the opposite side ensuring that both sides of the axle have been secured with the fixing pins and washers and that both sides of the operating frame are fixed. It should now be secure between the legs.

9. At this point it is important to ensure that the operating frame sits below the pedal and that the release catch hooks under the pedal as in **Fig. 17.10**. If necessary, adjust the operating frame to enable the release catch to hook onto the pedal.

## Operation

To operate the wheel kit press down on the pedal, **Fig. 17.11**. This motion raises the machine and stand. The release catch hooks onto the pedal allowing the machine to be wheeled freely around the workshop. To set the machine in position, press down on the release catch. This motion releases the wheels and lowers the leg stand to the floor.

# 17. Assembly of the Optional BDS250-W Pedal Wheel Kit

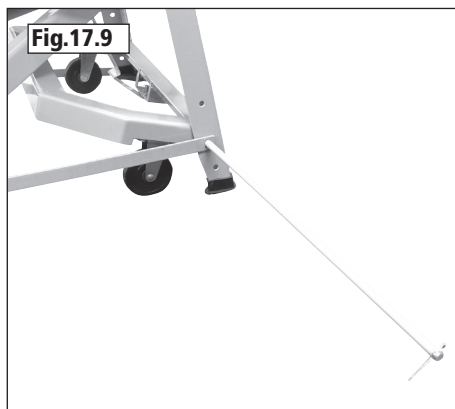
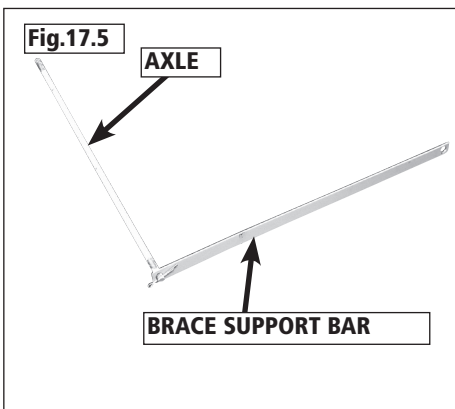
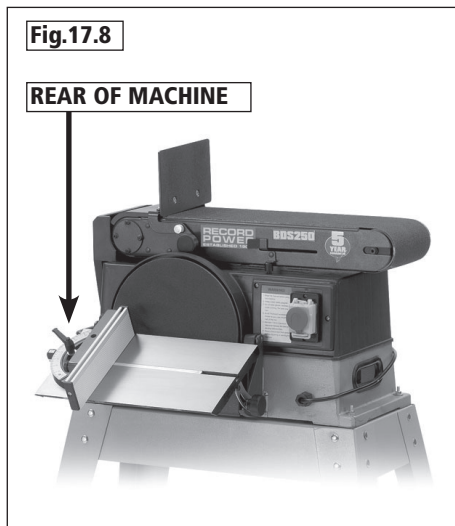
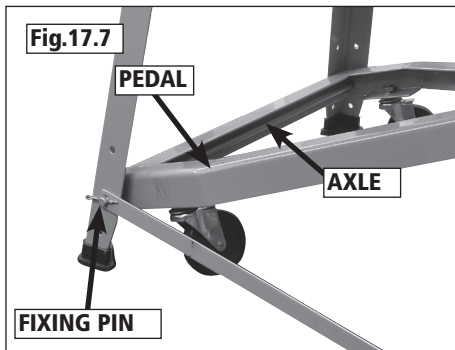
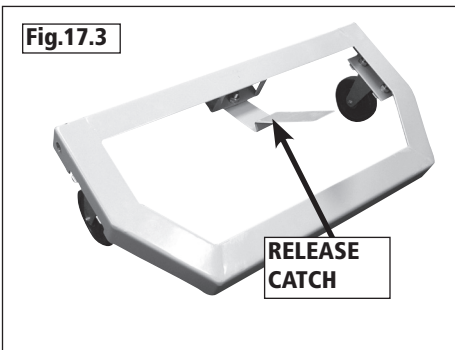
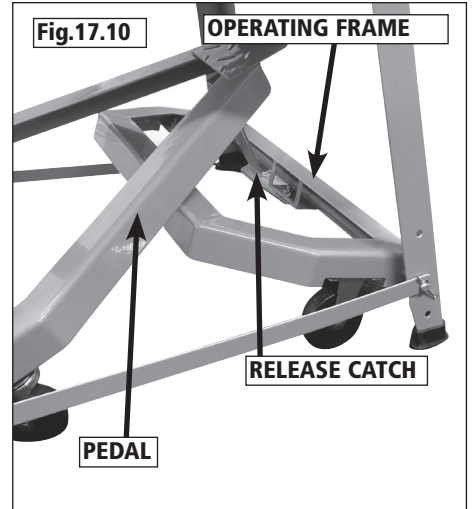
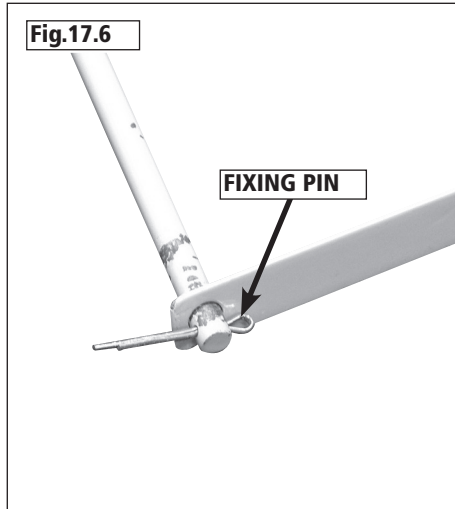
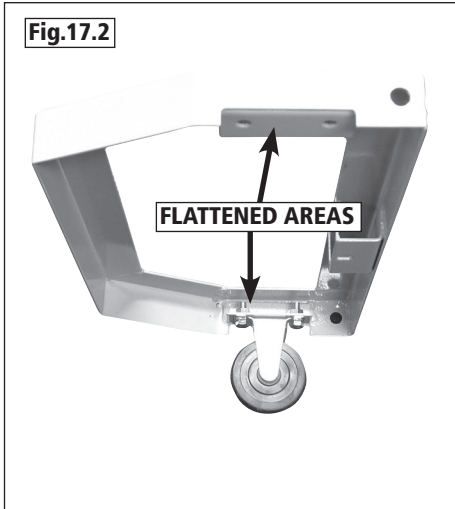



# EC Declaration of Conformity

**Cert No: EC / BDS250 / 3**

Record Power Ltd, Centenary House, 11 Midland Way, Barlborough Links, Chesterfield, Derbyshire, S43 4XA, United Kingdom

declares that the machinery described:

1. Type: **Belt and Disc Sander**
2. Model No: **BDS250**
3. Serial No: **Engineering Sample**

Will conform with the following standards:

MACHINERY DIRECTIVE: 2006/42/EC

ADDITIONAL USED EC DIRECTIVES: EMC Directive 2014/30/EU

USED HARMONIZED STANDARDS: EN 62841-1:2015  
EN ISO 12100:2010  
EN 55014-1: 2017  
EN 55014-2: 2015  
EN 61000-3-2:2014  
EN 61000-3-3:2013



and complies with the relevant essential health and safety requirements and conforms to the machinery example for which the EC Type-Examination certificate numbers **M8A171274171011** and **E8A074171 0014 Rev.00** have been issued at:  
TÜV SÜD Product Service GmbH, Zertifizierstelle, Ridlerstraße 65, 80339 München, Germany

Signed..........Dated: **06/05/2021** – Chesterfield / U.K.  
**Andrew Greensted**  
Managing Director

Technical file held by Andrew Greensted, Record Power Ltd, Centenary House, 11 Midland Way, Barlborough Links, Chesterfield, Derbyshire, S43 4XA, United Kingdom

EC	REP	Record Power B.V., Verlengde Poolseweg 16, 4818 CL BREDA, Netherlands, Tel: +31 76 52 44 766
----	-----	--

# UKCA Declaration of Conformity

**Cert No: UKCA / BDS250 / 1**

Record Power Ltd, Centenary House, 11 Midland Way, Barlborough Links, Chesterfield, Derbyshire, S43 4XA, United Kingdom

declares that the machinery described:

1. Type: **Belt and Disc Sander**
2. Model No: **BDS250**
3. Serial No: **Engineering Sample**

Will conform with the following standards:

MACHINERY DIRECTIVE:	2006/42/EC
ADDITIONAL USED EC DIRECTIVES:	EMC Directive 2014/30/EU
USED HARMONIZED STANDARDS:	EN 62841-1:2015 EN ISO 12100:2010 EN 55014-1: 2017 EN 55014-2: 2015 EN 61000-3-2:2014 EN 61000-3-3:2013



and complies with the relevant essential health and safety requirements and conforms to the machinery example for which the EC Type-Examination certificate numbers M8A171274171011 and E8A074171 0014 Rev.00 have been issued at:  
TÜV SÜD Product Service GmbH, Zertifizierstelle, Ridlerstraße 65, 80339 München, Germany

Signed..........Dated: **17/08/2021** – Chesterfield / U.K.  
**Andrew Greensted**  
Managing Director

Technical file held by Andrew Greensted, Record Power Ltd, Centenary House, 11 Midland Way, Barlborough Links, Chesterfield, Derbyshire, S43 4XA, United Kingdom





# **RECORD POWER**

ESTABLISHED 1909®

## Woodworking Machinery and Accessories

Record Power Ltd, Centenary House, 11 Midland Way, Barlborough Links, Chesterfield, Derbyshire S43 4XA

Tel: +44 (0) 1246 571 020 Fax: +44 (0) 1246 571 030 [www.recordpower.co.uk](http://www.recordpower.co.uk)

To register a product and find your local stockist visit

**[recordpower.info](http://recordpower.info)**

Made in China