

Original Instructions

BM16 Sliding Table Morticer

Version 3.4
November 2022



To register this product please visit
www.recordpower.info

It is important to register your product as soon as possible in order to receive efficient after sales support and be entitled to the full **5 year guarantee**. Your statutory rights are not affected. Please see back cover for contact details.



Always wear safety glasses when using woodworking equipment.



Always read the instructions provided before using woodworking equipment.

Important

For your safety read instructions carefully before assembling or using this product.

Save this manual for future reference.

Contents

- 1.1** Explanation of Symbols
- 1.2** General Health & Safety Guidance
- 2** Health & Safety Guidance for Morticing Machines
- 3** Record Power Guarantee
- 4** Specifications
- 5** Getting to Know your Machine
- 6** Contents of the Package
- 7a** Assembly - General
- 7b** Assembly - Chisel and Bit
- 8** Setting up the Machine
- 9a** Maintenance - General
- 9b** Maintenance - Chisel and Bit
- 10** Trouble Shooting
- 11** Dust Extraction
- 12** Parts List and Diagram
- EC Declaration of Conformity
- UKCA Declaration of Conformity

1.1 Explanation of Symbols

THE SYMBOLS AND THEIR MEANINGS SHOWN BELOW MAY BE USED THROUGHOUT THIS MANUAL. PLEASE ENSURE THAT YOU TAKE THE APPROPRIATE ACTION WHEREVER THE WARNINGS ARE USED.

Mandatory Instructions



Read and fully understand the instruction manual before attempting to use the machine.



Indicates an instruction that requires particular attention



Wear protective eyewear



Use respiratory protective equipment



Use hearing protection



Use suitable protective footwear



Use protective work gloves

Warning



Indicates a risk of severe personal injury or damage to the machine



Indicates a risk of severe personal injury from electrical shock



Risk of personal injury from lifting of heavy items



Indicates a risk of severe personal injury from airborne objects



Risk of fire

1.2 General Health & Safety Guidance

Ensure that you carefully read and fully understand the instructions in this manual before assembly, installation and use of this product. Keep these instructions in a safe place for future reference.

WARNING: for your own safety, do not attempt to operate this machine until it is completely assembled and installed according to these instructions.

WARNING: When using any machine, basic safety precautions should always be followed to reduce the risk of fire, electric shock and personal injury.

Safe Operation

1. Use Personal Protective Equipment (PPE)

- The operation of any machine can result in foreign objects being thrown into your eyes, which can result in severe eye damage. Protective eyewear or other suitable eye protection or face shield should be used at all times. Everyday spectacles only have impact resistant lenses. They are not protective eyewear and do not give additional lateral protection.
- Use respiratory protective equipment (dust mask etc.) if the machining operation creates dust. Exposure to high levels of dust created by machining hardwoods, softwoods and man made composite boards can result in serious health problems. Some imported hardwoods give off highly irritating dust, which can cause a burning sensation. The use of respiratory protective equipment should not be seen as an alternative to controlling the risk of exposure at source by using adequate dust extraction equipment.
- The use of ear plugs or ear defenders is recommended when the machine is in use, particularly if the noise level exceeds 85 dB.
- Wear suitable protective gloves when handling cutting tools or blades. Gloves should NOT be worn when using the machine as they can be caught in moving parts of the machine.
- Non-slip safety footwear is recommended when using the machine and handling large work pieces.

2. Dress appropriately

- Do not wear loose clothing, neckties or jewellery; they can be caught in moving parts of the machine.
- Roll up long sleeves above the elbow.
- Wear protective hair covering to contain long hair.

3. Safety warnings

- Find and read any warning labels on the machine
- It is important that any labels bearing health and safety warnings are not removed, defaced or covered. Replacement labels can be obtained by contacting our Customer Service Department.

4. Familiarise yourself with the machine

- If you are not thoroughly familiar with the operation of this machine, obtain advice from your supervisor, instructor, or other qualified person or contact your retailer for information on training courses. Do not use this machine until adequate training has been undertaken.

5. Take care when moving or positioning the machine

- Some machines can be very heavy. Ensure the floor of the area in which the machine is to be used is capable of supporting the machine.
- The machine and its various components can be heavy. Always adopt a safe lifting technique and seek assistance when lifting heavy components. In some cases it may be necessary to use mechanical handling equipment to position the machine within the work area.
- Some machines have optional wheel kits available to allow them to be manoeuvred around the workshop as required. Care should be taken to install these according to the instructions provided.
- Due to the nature of the design of some machines the centre of gravity will be high making them unstable when moved. Extreme care should be taken when moving any machine.
- If transportation of the machine is required then all precautions relating to the installation and handling of the machine apply. In addition, ensure that any vehicles or manual handling equipment used for transportation are of adequate specification.

6. The machine should be level and stable at all times

- When using a leg stand or cabinet base that is designed to be fitted to the machine, always ensure that it is securely fastened to the machine using the fixings provided.
- If the machine is suitable to be used on a workbench, ensure that the workbench is well constructed and capable of withstanding the weight of the machine. The machine should always be securely fastened to the workbench with appropriate fixings.
- Where possible, floor standing machines should always be secured to the floor with fixings appropriate to the structure of the floor.
- The floor surface should be sound and level. All of the feet of the machine should make contact with the floor surface. If they do not, either re-locate the machine to a more suitable position or use packing shims between the feet and the floor surface to ensure the machine is stable.

7. Remove adjusting keys and wrenches

- Ensure that all adjusting wrenches and keys are removed before switching the machine 'ON'. There is a risk of severe personal injury or damage to the machine from airborne objects.

8. Before switching the machine 'ON'

- Clear the machine table of all objects (tools, scrap pieces etc.)
- Make sure there is no debris between the work piece and the table / work support.
- Ensure that the work piece is not pressed against, or touching the saw blade or cutting tool.
- Check all clamps, work holding devices and fences to ensure that they are secure and cannot move during machining operations.
- Plan the way that you will hold and feed the work piece for the entire machining operation.

9. Whilst machining

- Before starting work, watch the machine while it runs. If it makes an unfamiliar noise or vibrates excessively, switch the machine 'OFF' immediately and disconnect it from the power supply. Do not restart until finding and correcting the source of the problem.

10. Keep the work area clear

- Working clearances can be thought of as the distances between machines and obstacles that allow safe operation of every machine without limitation. Consider existing and anticipated machine needs, size of material to be processed through each machine and space for auxiliary stands and/or work tables. Also consider the relative position of each machine to one another for efficient material handling. Be sure to allow yourself sufficient room to safely operate your machines in any foreseeable operation.
- Cluttered work areas and benches create the risk of accidents. Keep benches clear and tidy away tools that are not in use.
- Ensure that the floor area is kept clean and clear of any dust and debris that may create trip or slip hazards.

11. Consider the work area environment

- Do not expose the machine to rain or damp conditions.
- Keep the work area well lit and ensure that there is artificial lighting available when there is insufficient natural light to effectively light the work area. Lighting should be bright enough to eliminate shadow and prevent eye strain.
- Do not use the machine in explosive environments eg. in the presence of flammable liquids, gases or dust.
- The presence of high levels of dust created by machining wood can present a risk of fire or explosion. Always use dust extraction equipment to minimise the risk.

12. Keep other persons away (and pets)

- The machine is designed to be used by one person only.
- Do not let persons, especially children, touch the machine or extension cable (if used) and keep visitors away from the work area.
- Never leave the machine running unattended. Turn the power supply off and do not leave the machine unattended until it comes to a complete stop.

1.2 General Health & Safety Guidance

- If the work area is to be left unattended, all machinery should be switched 'OFF' and isolated from the mains power supply.

13. Store machines safely when not in use

- When not in use, machines should be stored in a dry place, out of reach of children. Do not allow persons unfamiliar with these instructions or with the machine to operate it.

14. Do not overreach

- Choose a working position that allows your body to remain balanced and feed the work piece in to the machine without overreaching.
- Keep proper footing and balance at all times.

15. Electrical supply

- Electrical circuits should be dedicated to each machine or large enough to handle combined motor amp loads. Power outlets should be located near each machine so that power or extension cables are not obstructing high-traffic areas. Observe local electrical guidelines for proper installation of new lighting, power outlets, or circuits.
- The machine must be connected to an earthed power supply.
- The power supply must be equipped with a circuit breaker that provides short circuit, overload and earth leakage protection.
- The voltage of the machine must correspond to the voltage of the mains power supply.
- The mains plug fitted to the machine should always match the power outlet. Do not modify the plug in any way. If a replacement plug is required it should be fitted by a competent person and of the correct type and rating for the machine.
- If you are unsure about any electrical connections always consult a qualified electrician.

16. Avoid unintentional starting of the machine

- Most machines are fitted with a no-volt release (NVR) switch to prevent unintentional starting. If in doubt always ensure the machine switch is in the 'OFF' position before connecting it to the power supply. This means the machine will not automatically start up after a power cut or switching on of the power supply, unless you first reset the start switch.

17. Outdoor use

- Your machine should not be used outdoors.

18. Extension cables

- Whenever possible, the use of extension cables is not recommended. If the use of an extension cable is unavoidable, then it should have a minimum core cross section of 2.5 mm² and limited to a maximum length of 3 metres.
- Extension cables should be routed away from the direct working area to prevent a trip hazard.

19. Guard against electric shock

- Avoid body contact with earthed or grounded surfaces such as pipes and radiators. There is an increased risk of electric shock if your body is earthed or grounded.

20. Always work within the machine's intended capacities

- Operator safety and machine performance are seriously adversely affected if attempts to make the machine perform beyond its limits are made.

21. Do not abuse the power cable

- Never pull the power cable to disconnect it from the power socket. Always use the plug.
- Keep the power cable away from heat, oil and sharp edges.
- Do not use the power cable for carrying or moving the machine.

22. Secure the work piece

- Ensure that the work piece is securely held before starting to machine it.
- When working within 300 mm of the machining area, always use a push stick to feed the work piece in to the blade or cutting tool. The push stick should have a minimum length of 400 mm. If the push stick becomes damaged, replace it immediately.
- Use extra supports (roller support stands etc.) for any work pieces large enough to tip when not held down to the table top.

- Do not use another person as a substitute for a table extension, or as additional support for a work piece that is longer or wider than the basic table, or to help feed, support, or pull the work piece.
- Do not attempt to machine more than one work piece at a time.
- When feeding the work piece towards the blade or cutting tool never position your hands in direct line of the cutting path. Avoid awkward operations and hand positions where a sudden slip could cause your hand or fingers to move into the machining area.

23. Stay alert

- Safety is a combination of operator common sense and alertness at all times when the machine is being used.
- Use all machines with extreme care and do not use the machine when you are tired or under the influence of drugs, alcohol or medication.

24. Use the correct tool for the job

- Do not use the machine for any purpose other than which it was designed.
- When selecting replacement cutting tools and blades, always ensure that they are designed to cut the material that you intend to use them for. If in any doubt seek further advice from the manufacturer.

25. Connect dust extraction equipment

- Always use dust extraction equipment. The dust extractor should be of suitable size and capacity for the machine that it is connected to and have a filtration level appropriate to the type of waste being collected. Refer to the relevant section of the manual for details of the specific dust extraction requirements for this machine.
- The dust extractor should be switched 'ON' before starting the machine that it is connected to. The dust extractor should be left running for 30 seconds after the last machining operation is complete in order to clear any residual waste from the machine.

26. Ensure that the machine is correctly guarded

- Never use the machine if any of the standard safety guards and equipment are removed or damaged.
- Some machines incorporate safety interlocks to prevent the machine from being used without the guards in place. Never attempt to bypass or modify the interlocks to allow the machine to be used without the guards in place.

27. Maintain your machine with care

- This manual gives clear instructions on installation, set up and operation of the machine and also details any routine and preventative maintenance that should be performed periodically by the user.
- Remember always to switch off and unplug the machine from the power supply before carrying out any setting up or maintenance operations.
- Follow any instructions for the maintenance of accessories and consumables.
- Do not use compressed air to clean the machine. Always use a brush to dislodge dust in places that are awkward to reach and a dust extractor to collect the waste.
- Inspect electric cables periodically and, if damaged, have them replaced by an authorised service facility or qualified electrician.
- Inspect extension cables (if used) periodically and replace if damaged.

28. Keep cutting tools sharp and clean

- Correctly maintained cutting tools are easier to control and less likely to bind.
- Cutting tools and blades can become hot during use. Take extreme care when handling them and always allow them to cool before changing, adjusting or sharpening them.

29. Disconnect the machine from the power supply

- When not in use, before servicing, changing blades etc. always disconnect the machine from the power supply.

30. Check for damaged parts

- Before each use of the machine, it should be carefully checked to determine that it will operate properly and perform its intended function.
- Check for alignment of moving parts, binding of moving parts, breakage

1.2 General Health & Safety Guidance

of parts and any other conditions that may affect the operation of the machine.

- A guard or other part that is damaged should be properly repaired or replaced by a qualified person unless otherwise indicated in this instruction manual.
- Do not use the machine if the switch does not turn the machine 'ON' and 'OFF'.
- Have defective switches replaced by a qualified person.

31. Warning!

- The use of any accessory or attachment, other than those recommended in this instruction manual, or recommended by our Company may present

a risk of personal injury or damage to the machine and invalidation of the warranty.

32. Have your machine repaired by a qualified person

- This machine complies with the relevant safety rules and standards appropriate to its type when used in accordance with these instructions and with all of the standard safety guards and equipment in place. Only qualified persons using original spare parts should carry out repairs. Failure to do this may result in considerable danger to the user and invalidation of warranty.

33. Caution! Motor may become hot during use

- It is normal for motors on some machines to become hot to the touch during use. Avoid touching the motor directly when in use.

2. Additional Health & Safety for Morticing Machines

Safe Operation

1. The morticer should be level and stable at all times

2. Familiarise yourself with the machine

- Machining operations using morticing machines have a history of serious accidents. Most result from trapping of hands or fingers between the chisel and the work piece or within the moving parts of the machine. Other minor accidents occur whilst setting, cleaning, adjusting or maintaining the machine.
- The machine is designed for morticing in hard and soft woods. It is not designed for use with any other material.
- Do not mount other tooling such as reamers, milling cutters, wire wheels or buffing wheels into the chuck.

3. Before switching the machine 'ON'

- Check that the chisel and bit are correctly installed and adjusted as detailed in the manual.
- Ensure that the work piece is securely held by the work clamp.
- Make sure there are no nails, screws or foreign objects in the part of the work piece to be machined.

4. Whilst machining

- Do not try to machine the full depth of the mortice in one pass. It is safer and will produce a better finished result if several passes are used.

- If re-positioning of the work piece within the work clamp is required during machining, switch the machine 'OFF' and wait for the motor to completely stop before making any adjustments.

- If you notice an increase in the noise level it is likely that either the chisel or the bit has moved within its mounting, causing greater contact between the two. If this happens, switch the machine 'OFF' and allow the chisel and bit to cool before attempting to make any adjustments.

- Do not place hands within 300 mm of the chisel and bit.

- Do not attempt to perform any machining operation when holding the work piece by hand.

- 5. This machine falls under the scope of the 'Health & Safety at Work etc. Act 1974', and the 'Provision & Use of Work Equipment Regulations 1998'. In addition the elimination or control of risks from wood dust is included in the above regulations and the 'Control of Substances Hazardous to Health (COSHH) Regulations 2002'. We recommend that you study and follow these regulations.

Further guidance is available from The Health & Safety Executive and their website www.hse.gov.uk.

3. Record Power Guarantee

“**Products**” means the Products sold by Record Power subject to these terms and conditions;

“**Record Power**” is Record Power Limited, whose company registration number is 4804158 and registered office address is Centenary House, 11 Midland Way, Barlborough Links, Chesterfield, Derbyshire, S43 4XA and sells through a network of Authorised Dealers;

“**Authorised Distributor**” is the nominated importer for your region who will generally sell through a network of Authorised Dealers. Details of Authorised Distributors for specific countries can be found in the Product manual or at www.recordpower.info;

“**Authorised Dealer**” is a retailer or business authorised to sell Record Power Products to end users.

1 Guarantee

- 1.1 Record Power guarantees that for a period of 5 years from the date of purchase the components of qualifying Products (see clauses 1.2.1 to 1.2.9) will be free from defects caused by faulty construction or manufacture.
- 1.2 During this period Record Power, its Authorised Distributor or Authorised Dealer will repair or replace free of charge any parts which are proved to be faulty in accordance with paragraphs 1.1 above provided that:
 - 1.2.1 you follow the claims procedure set out in clause 2 below;
 - 1.2.2 Record Power, our Authorised Distributor or Authorised Dealer are given a reasonable opportunity after receiving notice of the claim to examine the Product;
 - 1.2.3 if asked to do so by Record Power, its Authorised Distributor or Authorised Dealer, you return the Product, at your own cost, to Record Power’s premises or other approved premises such as those of the Authorised Distributor or supplying Authorised Dealer, for the examination to take place;
 - 1.2.4 the fault in question is not caused by industrial use, accidental damage, fair wear and tear, wilful damage, neglect, incorrect electrical connection, abnormal working conditions, failure to follow our instructions, misuse, or alteration or repair of the Product without our approval;
 - 1.2.5 the Product has been used in a domestic environment only;
 - 1.2.6 the fault does not relate to consumable Products such as blades, bearings, drive belts or other wearing parts which can reasonably be expected to wear at different rates depending on usage (for full details contact Record Power or your local Authorised Distributor);
 - 1.2.7 the Product has not been used for hire purposes, by you or by a previous owner;
 - 1.2.8 the Product has been purchased by you as the guarantee is not transferable from a private sale.
 - 1.2.9 where the Product has been purchased from a retailer, the 5 year guarantee is transferable and begins on the date of the first purchase of the Product and in the event of a claim under this guarantee proof of the original purchase date will be required to validate the warranty period.

2 Claims Procedure

- 2.1 In the first instance please contact the Authorised Dealer who supplied the Product to you. In our experience many initial problems with machines that are thought to be due to faulty parts are actually solved by correct setting up or adjustment of the machines. A good Authorised Dealer should be able to resolve the majority of these issues much more quickly than processing a claim under the guarantee.
- 2.2 Any damage to the Product resulting in a potential claim under the guarantee must be reported to the Authorised Dealer from which it was purchased within 48 hours of receipt.
- 2.3 If the Authorised Dealer who supplied the Product to you has been unable to satisfy your query, any claim made under this Guarantee should be made directly to Record Power or its Authorised Distributor (for details of the Authorised Distributor in your country please see your Product manual or check www.recordpower.info for details). The claim itself should be made in a letter setting out the date and place of purchase, and giving a brief explanation of the problem which has led to the claim. This letter should then be sent with proof of the purchase date (preferably a receipt) to Record Power or its Authorised Distributor. If you include a phone number or email address this will help to speed up your claim.
- 2.4 Please note that it is essential that the letter of claim reaches Record Power or its Authorised Distributor on the last day of this Guarantee at the latest. Late claims will not be considered.

3 Limitation of Liability

- 3.1 We only supply Products for domestic and private use. You agree not to use the Product for any commercial, business or re-sale purposes and we have no liability to you for any loss of profit, loss of business, business interruption or loss of business opportunity.
- 3.2 This Guarantee does not confer any rights other than those expressly set out above and does not cover any claims for consequential loss or damage. This Guarantee is offered as an extra benefit and does not affect your statutory rights as a consumer.

4 Notice

This Guarantee applies to all Products purchased from an Authorised Dealer of Record Power within the United Kingdom of Great Britain and Northern Ireland. Terms of Guarantee may vary in other countries – please check with the Authorised Distributor in your country (details of the Authorised Distributor for your country can be found in the manual or at www.recordpower.info).

4. Specifications

Table Size: 180 x 157mm

Table Height: 125mm

Maximum Drill Depth: 70mm

Maximum Workpiece Height: 120mm

Maximum Workpiece Depth: 125mm

Table Movement Side to Side: 160mm

Table Movement Front to Back: 60mm

Spindle Speed: 1400rpm

Chisel Capacity: 6 - 16mm

Chisel Shank: 13/16"

Maximum Chisel Stroke: 130mm

Distance from Fence to Centre of Chisel: 70mm

Chuck Capacity: 13mm

Motor: 1/2hp

Frequency: 50hz

Sound power level: < 85 dBA

Sound pressure level: < 85 dBA

5. Getting to Know Your Machine

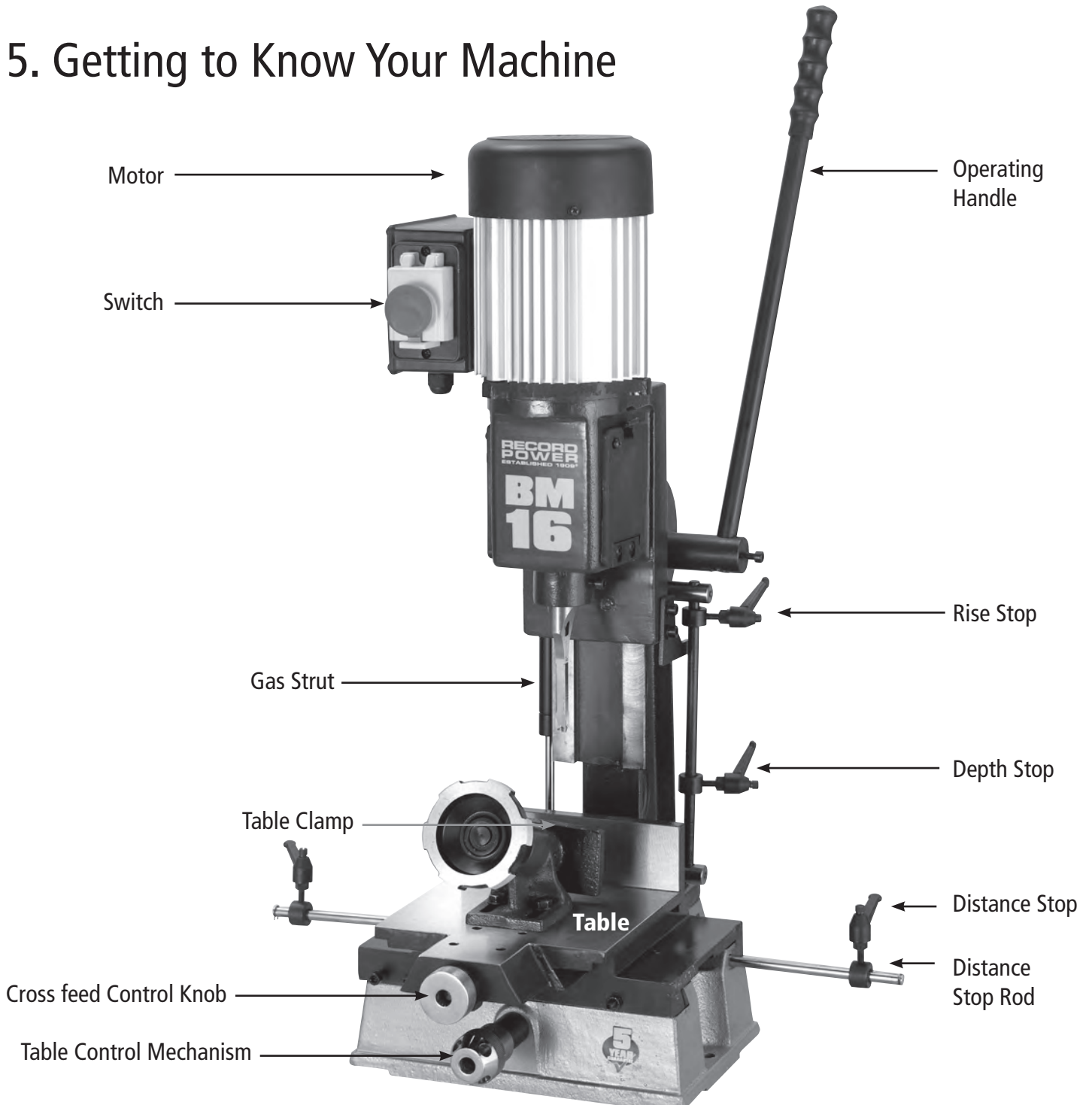

6. Contents of the Package

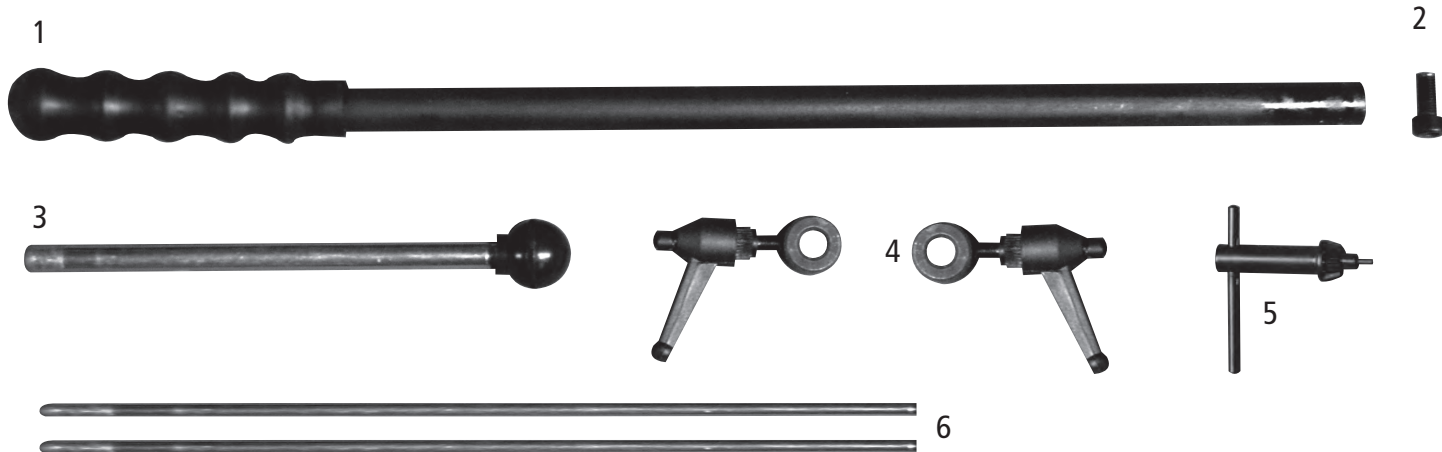

- 1 - Operating Handle
- 2 - Socket Head Cap Screw
- 3 - Table Control Lever
- 4 - Stops x2
- 5 - Chuck Key
- 6 - Distance Stop Rods x2
- 7 - BM16 Morticer

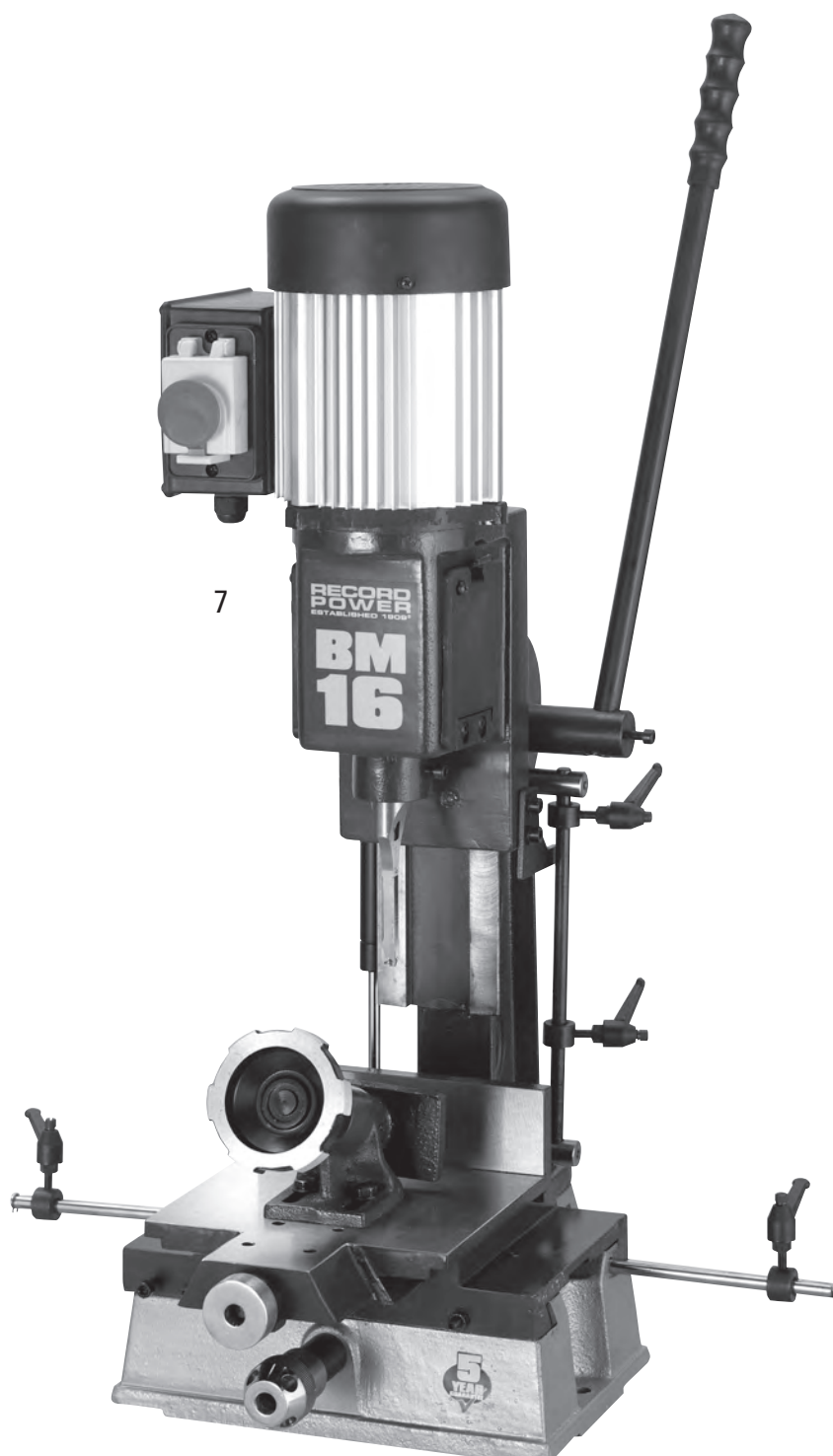

7a. Assembly - General

- 1) Remove the morticer from the shipping carton.
- 2) Place the machine onto a suitable surface, at a height that will enable you to work comfortably and to ensure that there is adequate room on either side for the size of timber you plan to use. When in position, bolt the morticer down.
- 3) Locate the operating lever and the grip sleeve, fit the sleeve over the end of the lever. (If it is difficult to slide on, try lubricating with a small amount of washing up liquid. Locate the M8 caphead screw, then introduce the operating lever through the rack and pinion assembly, then secure the lever in place using the M8 caphead screw. (See Pic 1)
- 4) Locate table control lever and screw into the table control mechanism (See Pic 2)
- 5) Take a distance stop rod and place in the hole on the side of the morticer base and secure with the grub screw as shown (See Pic 3)
Do not over tighten.
- 6) Attach a stop to the rod as shown. (See Pic 3)
- 7) Repeat the above steps to fit the remaining rod and stop to the opposite side of the machine.

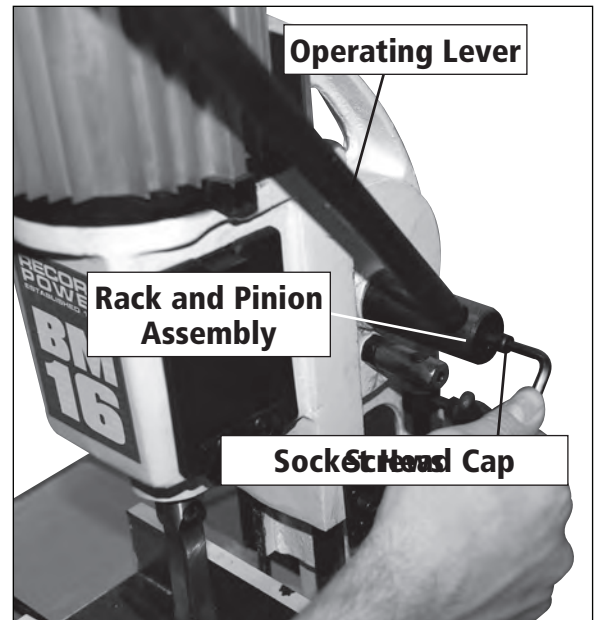

Pic 1

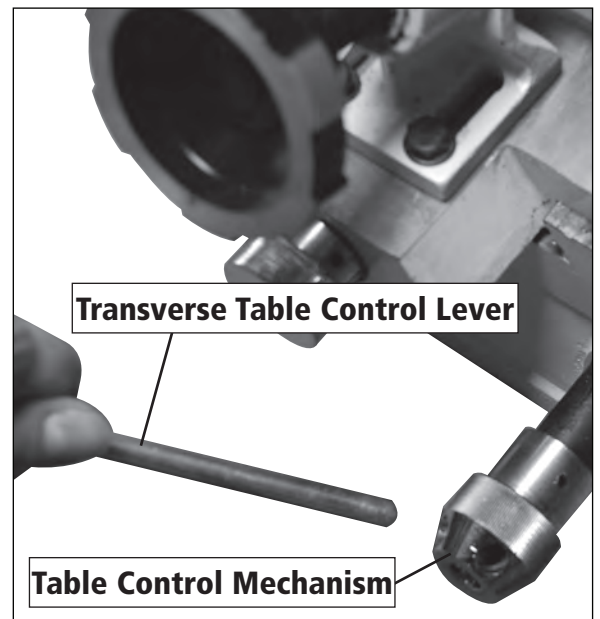

Pic 2

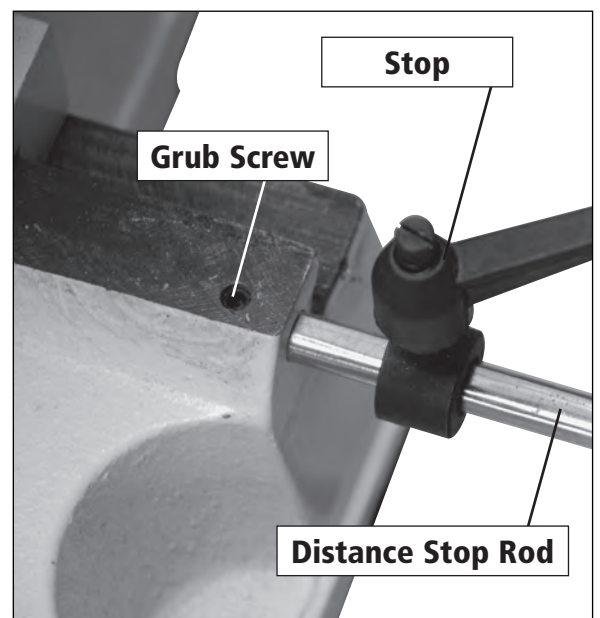

Pic 3

7b. Assembly - Chisel and Bit

- 1) Introduce the chisel into the adaptor collar, (Pic 4) press the auger up into the chuck.
- 2) Tighten the chuck and withdraw the chuck key. Gently pinch the chisel in place by finger tightening the clamping bolt. (See Pic 5)

Please Note

Various morticing machines require various bit shank lengths. A new bit has a shank of universal length which will be longer than needed. The shank of the bit is unhardened so it can be simply cut to length using a hacksaw. Carefully determine the necessary length, ensuring there is sufficient shank length to securely fix it into your machine chuck when set up with the correct clearance between chisel mouth and nose bit.

The correct setting of chisels and bits is vital for successful mortice cutting and long tool life.

Place the chisel into its socket in the chisel holder then put a coin about 1/16" (1.5mm) thick between the chisel shoulder and the chisel holder face to prevent the chisel being pushed fully home (see Pic 6) and tighten the chisel securing screw.

Put the bit into the drill chuck. Push it as far as possible into the chisel and secure the bit in the chuck. Loosen the chisel securing screw, remove the coin then push the chisel fully home in the chisel holder socket. Re-tighten the chisel securing screw.

This setting will allow sufficient clearance for the bit to run smoothly in the chisel and cut just ahead of the chisel. This set up allows the chips to pass inside the chisel body and exit through the slot in the chisel side. Position the chisel so that the chips are emptied into a previously cut part of the mortice (see Pic 6) .

Ensure the correct clearance between the chisel and bit is always maintained. Ensure the chisel and bit are securely held in the chisel holder and chuck. If the bit is not tightly secured it may move up into the mouth of the chisel during use. The side lips of the bit will rub against the chisel, the wood chips will not be able to pass up the inside of the chisel and out through the side slot. This will eventually cause the chisel to break.

It is recommended that for best results only Record Power chisels and bits should be used in this machine.

WARNING: Ensure chuck key is removed from chuck before switching 'ON' machine. Failure to do so could result in ejection of chuck key leading to personal injury of the operator.

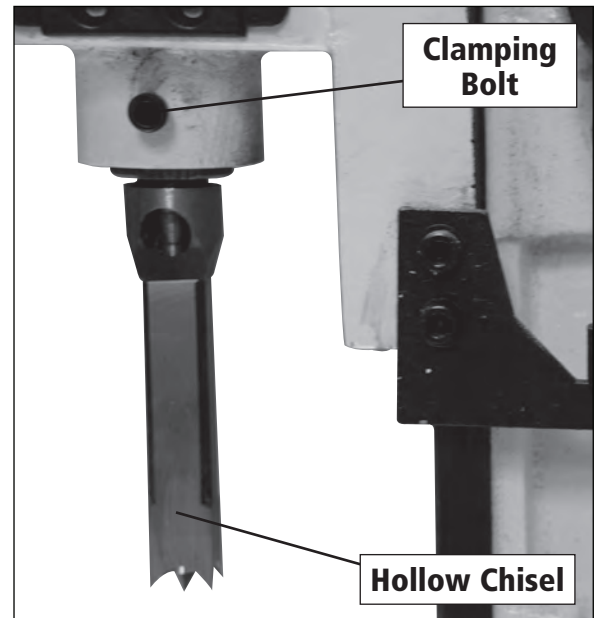

Pic 4

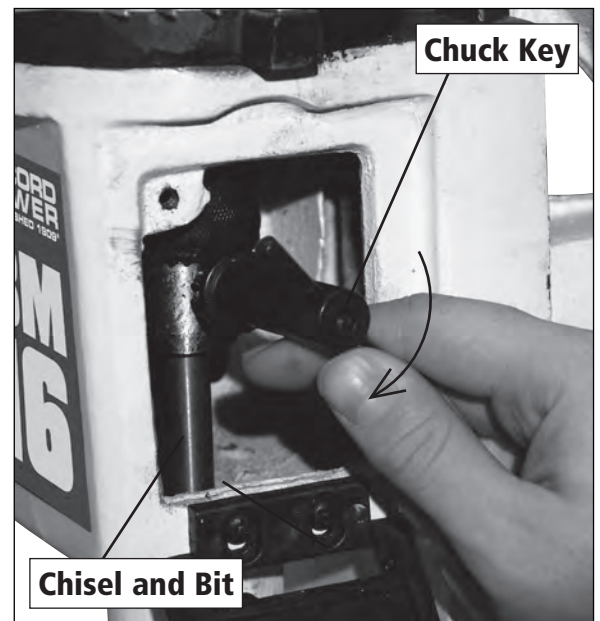

Pic 5

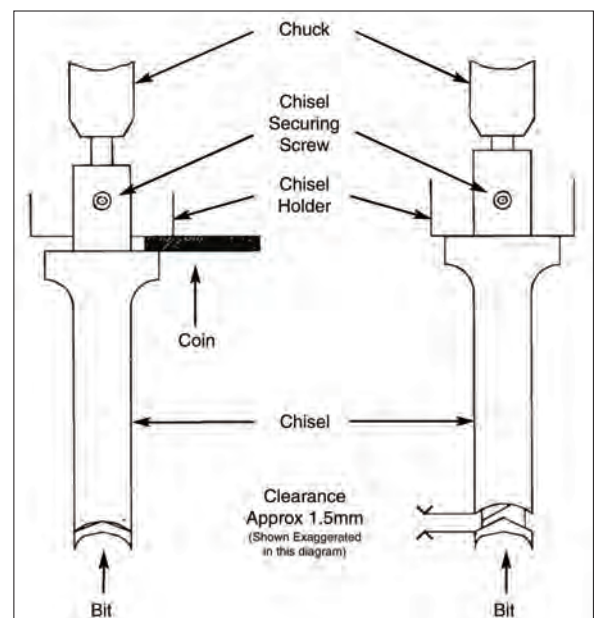

Pic 6

8. Setting Up the Machine

General Notes

The mortise will generate a lot of 'grip' on the chisel, especially the first cut, or if the timber is a little green. Make sure you use the table clamp assembly to help control the timber during the raise operation of the morticer.

Setting the chisel Square

When the chisel is tightened in the machine it must normally be square to the back fence (Pic 7). The easiest way to achieve this is to bring the head box down to bring the chisel as close to the table as possible, set a square against the back fence and set the side of the chisel against the square and clamp tight. (Remember to have the chip ejection slot in the chisel to the side from which you will cut the mortice).

Quick Setting of the Mortice Depth

Put a mark on an easily accessible end of the workpiece to be mortised, at the depth you require. Pull the head box down, and put the end of the timber against the chisel, position the head box so that the chisel points or the auger point are at the depth required (Pic 8), raise the depth stop collar to the underside of the head box and tighten gently. Recheck the depth of the chisel point, if it is satisfactory tighten securely, if not it can be gently 'nudged' down the column with the head box, then tighten. Reposition the operating handle to give the most comfortable position and purchase on the lever, over the full distance of the movement you have just set.

Head box Rise Adjustment

Coupled with the depth stop on the same assembly is the head box rise limiter. This limits the rise of the head box / chisel to a convenient distance above the work by the use of a locking collar positioned above the stop finger on the side of the head box (Pic 9). The travel of this assembly is then restricted to your chosen setting rather than having to return it to the top of the slide each time.

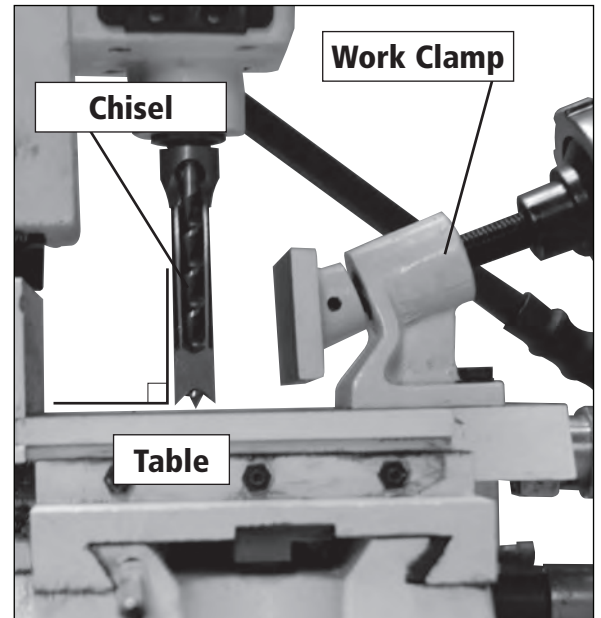

Pic 7

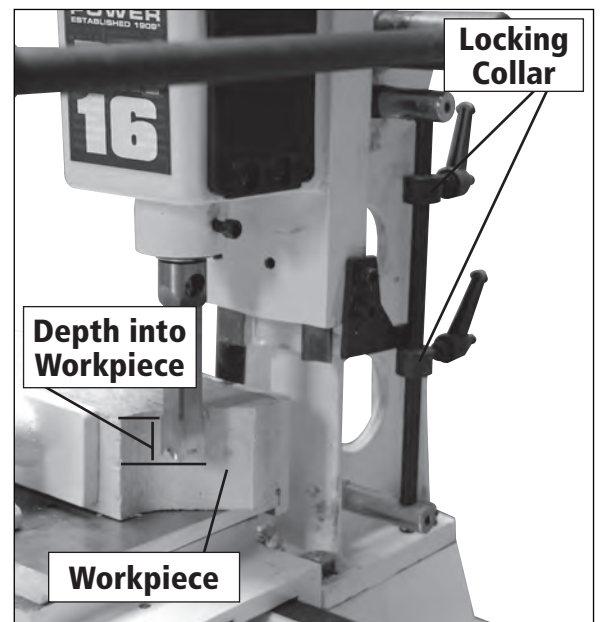

Pic 8

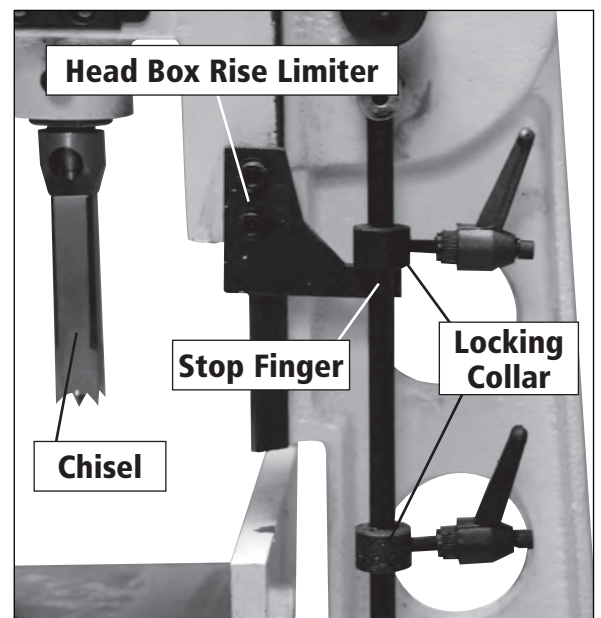

Pic 9

9a. Maintenance - General

There is very little maintenance required on your morticer.

Keep it clean

- Make sure the rack and pinion gears do not become clogged with chips/sawdust also keep well lubricated to prevent wear on the gears. (See Pic 10)
- Lightly spray oil on all exposed metal surfaces if the machine is going to stand idle for any length of time. Keep the chisels and augers sharp.

Once a month

- Blow/suck the motor to remove any debris that might have lodged in the fan cover.
- Oil the chuck and exercise it over its full range to ensure the oil coats all moving parts. (See Pic 11)

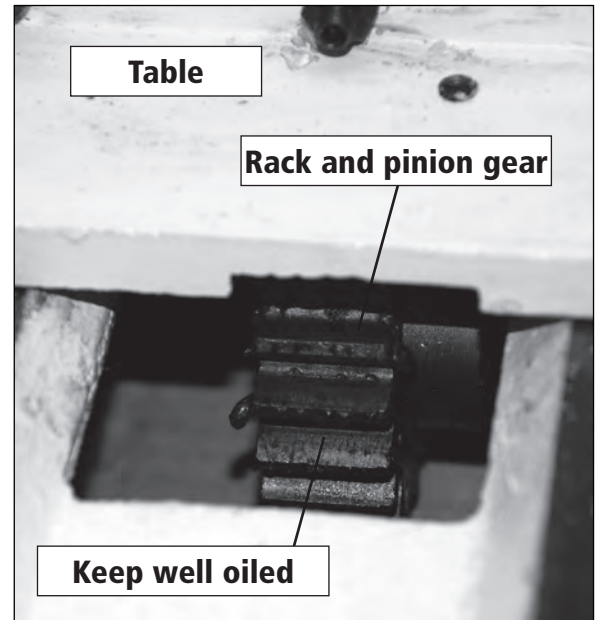
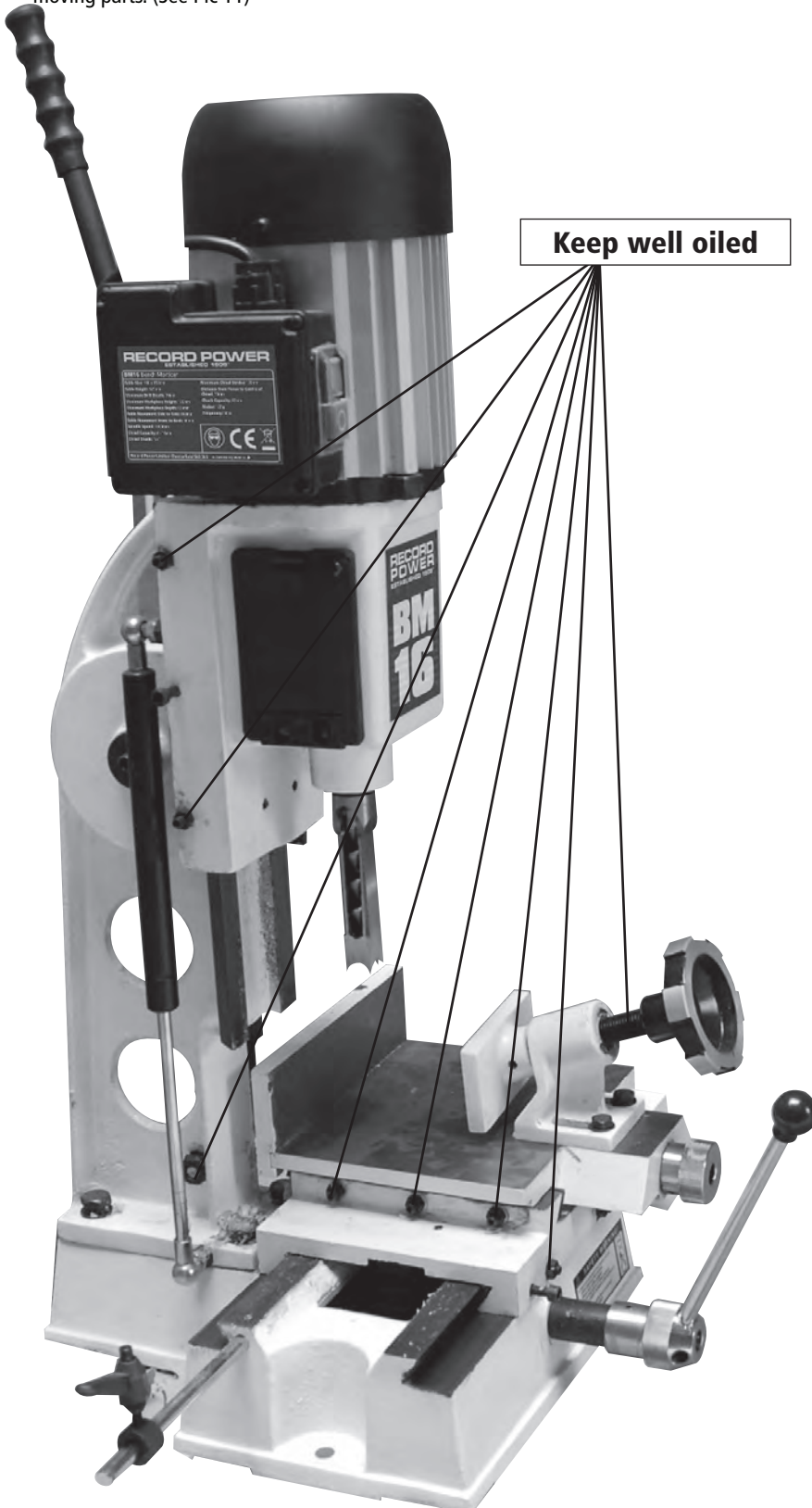

Pic 10

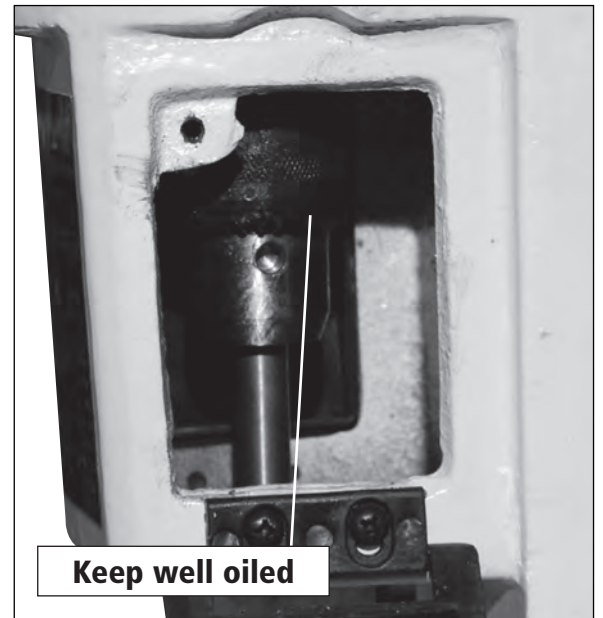

Pic 11

9b. Maintenance - Chisel and Bit

Chisel Abrasion

Look downward into the hollow of the chisel, check to see whether any of the bevelled areas inside the chisel (where hollow becomes circular) have dulled or any of the square corners have become round (Pic 10). The angles of the corners should be filed to regain the original shape.

When abrasion occurs to the extent of making the thickness of the entire chisel bit tip noticeably thin, the chisel bit will be liable to break in operation. When you see excessive abrasion, it is advisable to replace the chisel with a new one.

To sharpen the chisel, a special chisel sharpening tool is required (Pic 11).

Part numbers for ordering these tools
R539 Set 1 (suitable for 1/4" - 9/16")
R539 Set 2 (suitable for 5/8" - 1")

There are two types of chisel sharpening tool available. One has a fixed pilot which fits exactly into the chisel bore (each separate chisel must have a countersink with a pilot to suit each size). The other has interchangeable pilots which are held in place by a socket screw and locked with an Allen key.

The use of this tool ensures that all four cutting edges will be evenly sharpened and maintained in the correct shape and bevel.

1. Place the chisel carefully in a vice.
2. Fit the tool into a brace. Several turns of the tool will produce a fine cutting edge. The inside corners of the chisel must be finished with a fine file.

Never grind a chisel. Never sharpen it on the outside. Always protect it from possible damage.

Sharpening The Chisel And Bit

A well sharpened bit will cut fine broken chips which pass easily and quickly through the twist and are ejected through the slot in the chisel side.

1. To sharpen the spur (Pic 12) use a small square or flat smooth file and sharpen the inside only (Pic 13).

Never sharpen or stone the bit on the outside or attempt to grind it. If any doubts exist as to the suitability of the bit after prolonged use and repeated sharpening. Discard it and purchase a new one. The chisel is the more expensive component and a bad bit will impose great strain on the chisel.

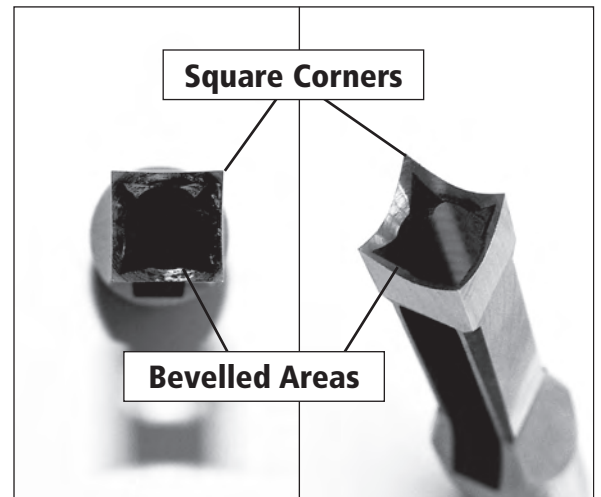

Pic 10

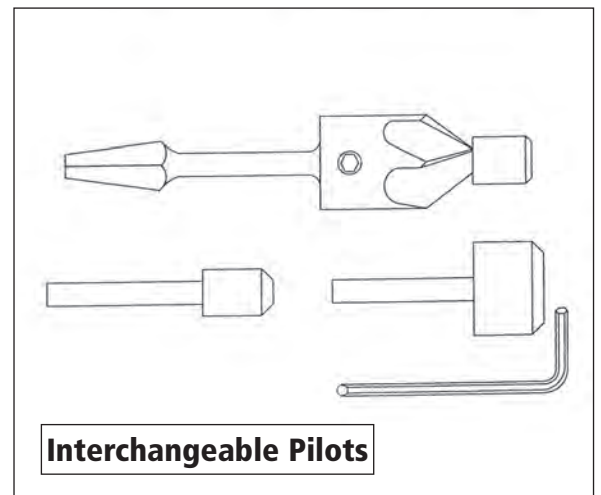

Pic 11

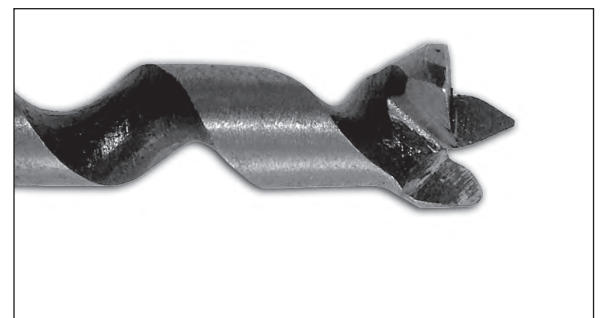

Pic 12

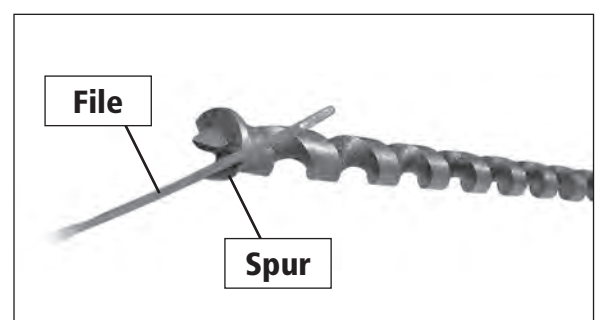

Pic 13

10. Trouble Shooting

Should you have any difficulty arise during operation, check the power cord and connection. If the problem does not appear to be related to the power supply, the following table may help to identify it.

IMPORTANT

Disconnect the machine from the power supply before servicing the machine.

Symptom	Possible Causes	Solutions
Morticer will not start	1. Fuse blown or circuit breaker tripped.	1. Replace fuse or reset circuit breaker.
	2. Cord damaged.	2. Have cord replaced by an Authorised Service Centre or Service Station.
Overload kicks out frequently	1. Extension cord too light or too long.	1. Replace with adequate size cord.
	2. Chisel and bit in poor condition (dull or broken).	2. Clean or replace the chisel and bit.
	3. Stock is too wet.	3. Dry stock for cutting.
Bit does not come up to speed	1. Extension cord too light or too long.	1. Replace with adequate size cord.
	2. Low current.	2. Contact your electrician.
	3. Motor not wired for correct voltage.	3. Refer to motor name plate for correct wiring.
Morticer makes unsatisfactory cuts	1. Dull hollow square chisel and bit.	1. Sharpen or replace the chisel and bit.
	2. Gum or pitch on the chisel and bit.	2. Remove the chisel and bit and clean with turpentine and steel wool.
	3. Gum or pitch on the worktable or fence causing un-square cutting.	3. Clean the worktable and fence with turpentine.
	4. The chisel and bit was not correctly set.	4. Make sure the entire assembly is correctly held with proper clearance of 2mm-5mm.
The work burns	1. Dull chisel and bit. 2. The bit has worn out or is-broken.	1. Sharpen or replace the chisel and bit. 2. Replace the worn bit with a new one.
The bit is down drilling	1. The bit is worn out or broken.	1. Replace the worn bit with a new one.
	2. The bit is not sharp enough.	2. Sharpen the bit.
	3. The drill chuck has been loosened to clamp the drill bit.	3. Tighten the drill chuck with the key provided.
The machine vibrates excessively	1. Damaged chisel bit.	1. Replace the damaged bit with a new one.
	2. Stand on uneven floor.	2. Reposition on flat level surface. Fasten to floor if possible.

11. Dust Extraction

The Importance of Dust Extraction

Suitable dust extraction is essential to avoid the possibility of serious health problems related to wood dust. It is also necessary in order to ensure the waste producing machine performs safely and effectively. Some woods are extremely toxic and in addition to suitable dust extraction machines it is recommended that PPE such as respirators are also used.

Record Power Dust Extraction Machines

Below is a summary of the Record Power range. Please visit your local stockist or go online for full details.

CGV286 CamVac Series Compact Extractor

36 litre capacity, 1 kW single or twin motor, 0.5 micron filtration. Includes hose.

CGV286-3-WALL CamVac Series Wall Mounted Extractor

150 litre capacity, twin motor, 0.5 micron filtration. Includes hose.

CGV336 CamVac Series Medium Extractor

55 litre capacity, 1 kW single or twin motor, 0.5 micron filtration. Includes hose.

CGV386 CamVac Series Large Extractor

90 litre capacity, 1 kW twin or triple motor, 0.5 micron filtration. Includes hose.

CGV486 CamVac Series Heavy Duty Extractor

200 litre capacity, 1 kW triple motor, 0.5 micron filtration. Includes hose.

DX1000 Fine Filter 45 Litre Extractor

45 litre capacity, 1 kW motor, 0.5 micron filtration. Includes hose. Includes hose.

AC400 2 Stage Air filter with Remote, 3 speeds and Time Delay

Collects airborne dust, 1 micron filtration.

	Bandsaws	Table Saws	Planer Thicknessers	Lathes	Sanding Machines	Dust Extraction Systems	Airborne Dust Collection
DX1000	✓	✓	✓	✓	✓		
CGV286	✓	✓	✓	✓	✓		
CGV286-3-WALL	✓	✓	✓	✓	✓	✓	
CGV336	✓	✓	✓	✓	✓		
CGV386	✓	✓	✓	✓	✓	✓	
CGV486	✓	✓	✓	✓	✓	✓	
AC400							✓

12. Parts List and Diagram

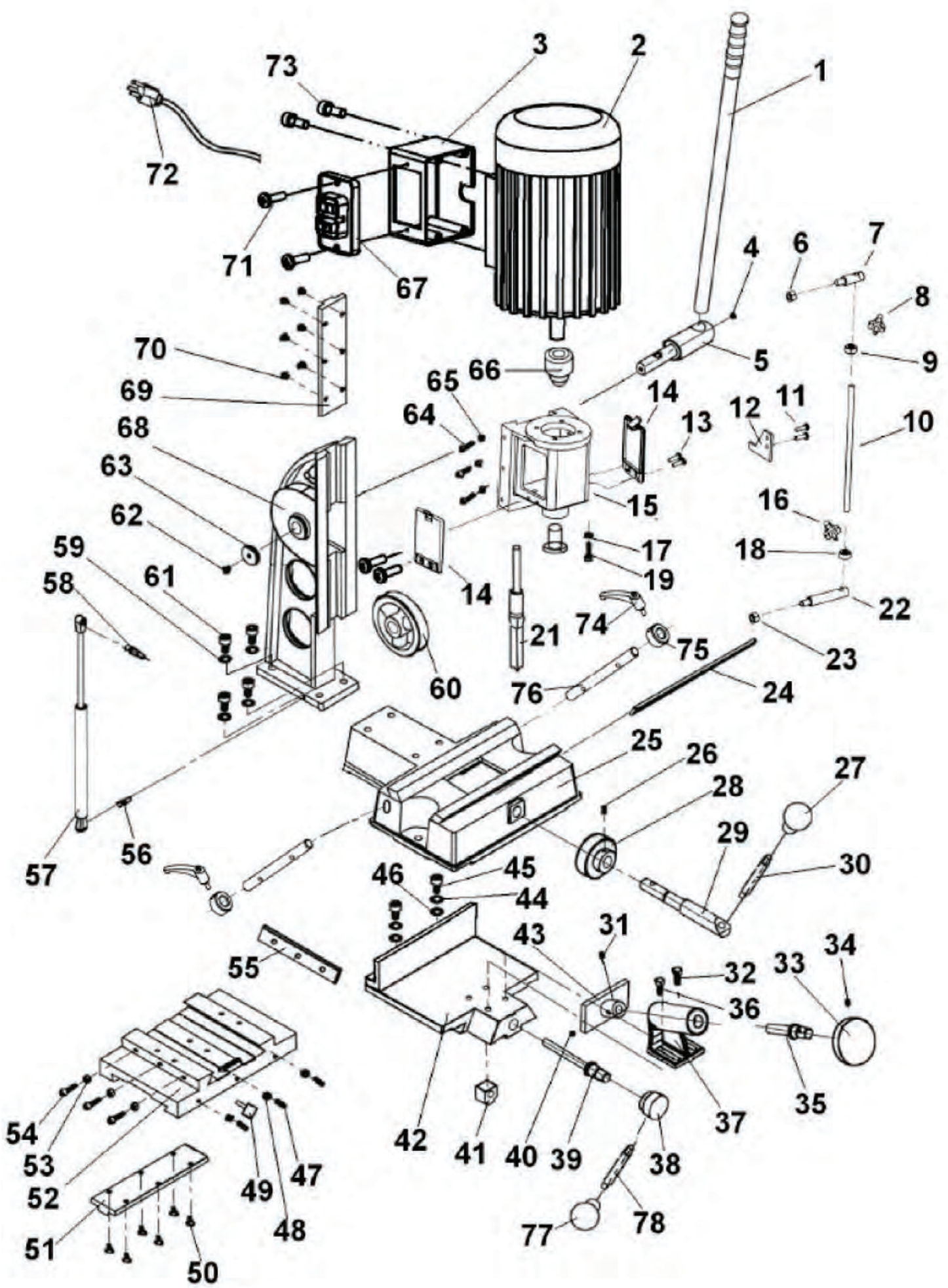

12. Parts List and Diagram

NO.	Description	Quantity	NO.	Description	Quantity
1	Handle	1	41	Lead Nut	1
2	Motor	1	42	Table	1
3	Switch Box	1	43	Clamp Plate	1
4	Screw	1	44	Screw	2
5	Gear Shift	1	45	Spring Washer	2
6	Screw	1	46	Washer	2
7	Screw	1	47	Screw	1
8	Handle	1	48	Nut	2
9	Setting Collar	1	49	Screw	1
10	Guide Column	1	50	Screw	1
11	Screw	2	51	Rack	1
12	Localizer	1	52	Sliding Plate	1
13	Screw	2	53	Washer	3
14	Cover	2	54	Screw	3
15	Gear Casing	1	55	Drift	4
16	Handle	1	56	Screw	4
17	Washer	4	57	Gas Spring	1
18	Setting Collar	1	58	Screw	1
19	Bolt	4	59	Washer	4
21	Chisel	1	60	Gear	1
22	Screw	1	61	Bolt	4
23	Nut	1	62	Screw	1
24	Drift	1	63	Drift	1
25	Base	1	64	Screw	3
26	Screw	2	65	Washer	3
27	Knob	1	66	Chuck	1
28	Gear	1	67	Switch	1
29	Gear Shaft	1	68	Column	1
30	Handle	1	69	Rack	1
31	Screw	1	70	Screw	6
32	Screw	1	71	Screw	2
33	Knob	1	72	Power Cord	1
34	Screw	1	73	Screw	4
35	Lead Screw	1	74	Handle	2
36	Screw	1	75	Chisel Bushing	2
37	Connecting Bend	1	76	Shaft	2
38	Knob	1	77	Knob	1
39	Lead Screw	1	78	Shaft	1
40	Screw	1			

EC Declaration of Conformity

Cert No: EC / BM16 / 3

Record Power Ltd, Centenary House, 11 Midland Way, Barlborough Links, Chesterfield, Derbyshire, S43 4XA, United Kingdom

declares that the machinery described:

1. Type: **Morticer**

2. Model No: **BM16**

3. Serial No: **20200723**

Will conform with the following standards:

MACHINERY DIRECTIVE: 2006/42/EC

ADDITIONAL USED EC DIRECTIVES: EMC Directive 2014/30/EU

USED HARMONIZED STANDARDS: EN 61029-1:2009+A11



and complies with the relevant essential health and safety requirements and conforms to the machinery example for which the EC Type-Examination certificate numbers

AM 50476859 0001 and **AE 50464174 0001**

have been issued at:

TÜV Rheinland LGA Products GmbH, Tilystraße 2, 90431 Nürnberg, Germany

Signed..........Dated: **06/05/2021** – Chesterfield / U.K.

Andrew Greensted
Managing Director

Technical file held by Andrew Greensted, Record Power Ltd, Centenary House, 11 Midland Way, Barlborough Links, Chesterfield, Derbyshire, S43 4XA, United Kingdom

<table border="1"><tr><td>EC</td><td>REP</td></tr></table>	EC	REP	Record Power B.V., Verlengde Poolseweg 16, 4818 CL BREDA, Netherlands, Tel: +31 76 52 44 766
EC	REP		

UKCA Declaration of Conformity

Cert No: UKCA / BM16 / 2

Record Power Ltd, Centenary House, 11 Midland Way, Barlborough Links, Chesterfield, Derbyshire, S43 4XA, United Kingdom

declares that the machinery described:

1. Type: **Morticer**

2. Model No: **BM16**

3. Serial No: **Engineering sample**

Will conform with the following standards:

TEST STANDARDS: EN ISO 12100:2010
 EN 62841-1:2015



and complies with the relevant essential health and safety requirements and conforms to the machinery example for which the UKCA Type-Examination certificate number **CN22PE4I 001** has been issued at:
TUV Rheinland UK Ltd., Friars Gate (Third Floor), 1011 Stratford Road, Shirley, Solihull, B90 4BN

Signed.....Dated: **29/09/2022** – Chesterfield / U.K.
Andrew Greensted
Managing Director

Technical file held by Andrew Greensted, Record Power Ltd, Centenary House, 11 Midland Way, Barlborough Links, Chesterfield, Derbyshire, S43 4XA, United Kingdom



Over
100
years

Experience • Knowledge
Support • Expertise

RECORD POWER
ESTABLISHED 1909®

Woodworking Machinery and Accessories

Record Power Ltd, Centenary House, 11 Midland Way, Barlborough Links, Chesterfield, Derbyshire S43 4XA

Tel: +44 (0) 1246 571 020 Fax: +44 (0) 1246 571 030 www.recordpower.co.uk

To register a product and find your local stockist visit

recordpower.info

Made in China